



### Device Information

Model Name	VCXU.2-127C
Vendor Name	Baumer

### Sensor Information

Sensor Name	Sony IMX545 Gen4
Type	1/1.1" progressive scan CMOS
Shutter	Global Shutter
Resolution	4096 x 2992 pixels
Scan Area	11.22 mm x 8.19 mm
Pixel Size	2.74 $\mu\text{m}$ x 2.74 $\mu\text{m}$

### Data Quality

@ 20 °C, gain = 1, exposure time = 4 msec

Dark Noise ( $\sigma$ )	2.5 e- typical
Saturation	9000 e- typical
Dynamic Range	70 dB typical
SNR	40 dB typical
Quantum efficiency $\eta$	42% @ 465 nm, 49% @ 536 nm, 39% @ 631 nm typical

### Acquisition

Resolution	4096 px x 2992 px		
Interface Frame Rate (depends on used interface performance)	Format	Resolution	max. Frame Rate (@ Trigger Mode) <sup>2)</sup>
	Full Frame	4096 x 2992	31 fps
	Binning 2x2	2048 x 1496	31 fps
	Binning 2x1	2048 x 2992	31 fps
	Binning 1x2	4096 x 1496	31 fps

Acquisition Frame Rate <sup>1)</sup>	31 fps   $t_{\text{readout}} = 31.8 \text{ msec}$ (max. Res. Full Frame) @ 10 bit
	25 fps   $t_{\text{readout}} = 39.1 \text{ msec}$ (max. Res. Full Frame) @ 12 bit

Pixel Formats	BayerRG8, BayerRG10, BayerRG12, BayerRG12p Mono8, Mono10, Mono12, Mono12p, RGB8, BGR8
---------------	--

Partial Scan	True Partial Scan with increasing Frame Rate on Y direction, Region of Interest (ROI) arbitrary Width: minimum 16, increment 16 Height: minimum 2, increment 2
--------------	--

Adjustable Acquisition Frame Rate	Off or 0.01 ... 65535 Hz
Acquisition Mode	Continuous, Single Frame and Multi Frame
Acquisition Status	AcquisitionActive, AcquisitionTrigger Wait
Exposure Mode	Timed
Shutter Mode	Global
Readout Mode	Sequential

### Image Pre-Processing

Analog Controls	Exposure Time (1 $\mu\text{sec}$ ... 60 sec   Step Size 1 $\mu\text{sec}$ ) Gain (0...48 dB), Offset (0 ... 255 LSB   12 bit)
Auto Function	ExposureAuto and GainAuto with BrightnessAutoPriority based on BrightnessAuto ROI BalanceWhiteAuto and ColorTransformationAuto based on BalanceWhiteAuto ROI
Gamma Correction	Gamma (0.1 ... 2   available if LUT is enabled)
LUT	Luminance (12 bit)
Color Models	Mono, Raw Bayer, RGB and BGR
Color Processing	Integrated color processor for high quality color calculation
Color Enhancement	Color Transformation to sRGB color space by optimized Matrix for 3000 K, 5000 K, 6500 K and 9500 K Lightsource or User defined Matrix

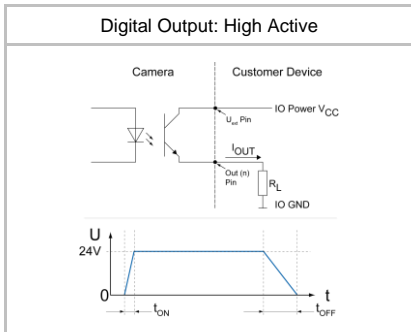
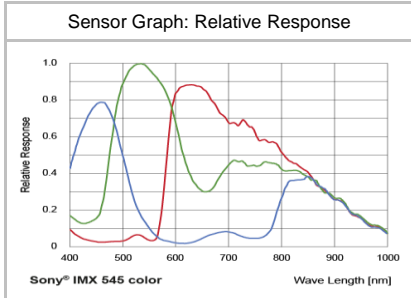

<sup>1)</sup> Sensor readout, different from pixel format

<sup>2)</sup> depends on the used interface

### Digital Output: Low Active

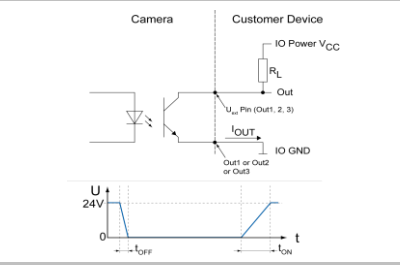

### Digital Input

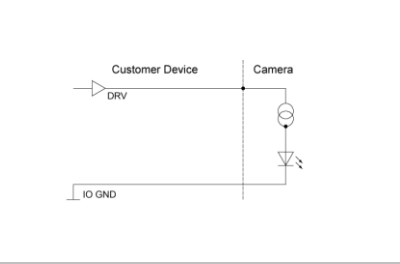

### Trigger Mode: Start up time and valid Trigger

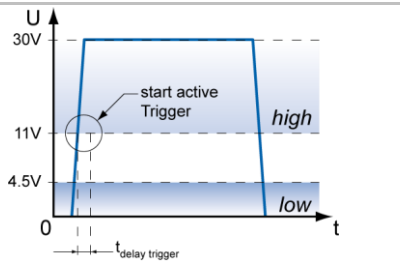

### GPIO

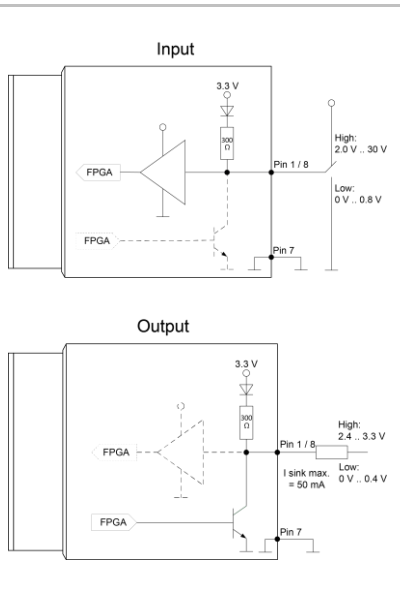

<sup>1)</sup> Sensor readout, different from pixel format

## Image Pre-Processing

Color Tolerance	-
Binning Horizontal	1 or 2
Binning Vertical	1 or 2
Defect Pixel Correction	via Defect Pixel List with up to 512 Pixel Coordinates
Image Flipping	Horizontal, vertical
Fix Pattern Noise	-
Correction	-

## Process Synchronization

Trigger Mode	Off (Free Running), On (Trigger)
Trigger Overlap Type	Readout
Trigger Sources	Hardware (Line0, 1, 2), Software, Counter 1, 2 End, All or Off
	fixed Trigger Delay out of treadout: <sup>1)</sup>
	134.4 μsec @ 8 bit
	134.5 μsec @ 10 bit
	165.4 μsec @ 12 bit
	max. Trigger Delay during treadout: <sup>1)</sup>
	134.4 μsec @ 8 bit
	134.5 μsec @ 10 bit
	165.4 μsec @ 12 bit
Trigger Delay	0 ... 2 sec, Tracking and buffering of up to 256 triggers
External Flash Sync	via Exposure Active
	t <sub>delay flash</sub> ≤ 3 μsec, t <sub>duration</sub> = t <sub>exposure</sub>
Encoder Function	yes, via Counter and Trigger Source
PTP Function	-

## Digital I/Os

Lines	Input: Line 0, Output: Line3, GPIO: Line 1, Line 2
Line Sources (Output)	Off, ExposureActive, Timer1, ReadoutActive, UserOutput 1-3 and TriggerReady
Line Debouncer (Input)	Low and high signal separately selectable
	Debouncing Time 0 ... 5 msec, Step Size: 1 μsec

## Memory

Image Buffer	912 MB
	26 Images (Trigger Mode) / 1 Image (Free Running Mode)
Non-volatile Memory	128 kb

## Interface Data

Interface	USB3.0 (5000 Mbits/sec)
USB Vendor ID / Product ID	0x2825 / 0x0171

## USB 3 Vision® Features

Events	DeviceTemperatureStatusChanged, EventLost, ExposureEnd, ExposureStart, FrameEnd, FrameStart, FrameTransferSkipped, Line0..2 FallingEdge, Line0..2 RisingEdge, TransferBufferFull, TransferBufferReady, TriggerOverlapped, TriggerReady, TriggerSkipped
Transmission via Asynchronous Message Channel	up to 2 <sup>32</sup>
Frame Counter	0 ... 36765920 Byte
Payload Size	0 ... 36765920 Byte
Timestamp	64 bit, resolution in nsec, increment = 8
USB Vision	v1.0.1

## Interfaces and Connectors

Data and Power Interface	USB 3.0	Transfer Rate	5000 Mbits/sec
	USB 2.0	Transfer Rate	480 Mbits/sec
	Connector:		USB 3.0 Micro B
Pin Assignment:	1 - VBUS	2 - D-	
	3 - D+	4 - ID	
	5 - GND	6 - MicB_SSTX-	
	7 - MicB_SSTX+	8 - GND_DRAIN	
	9 - MicB_SSRX-	10 - MicB_SSRX+	

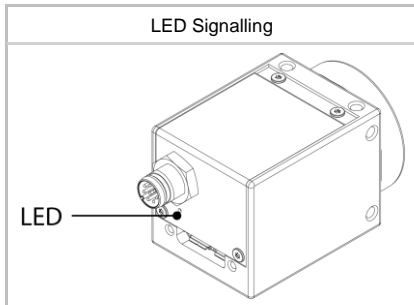
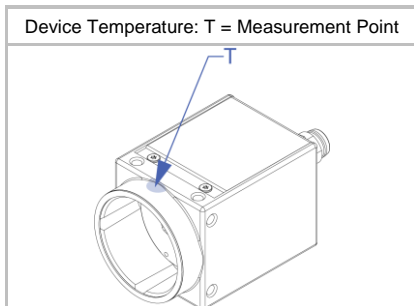
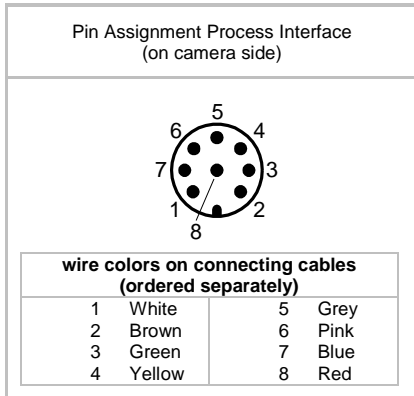
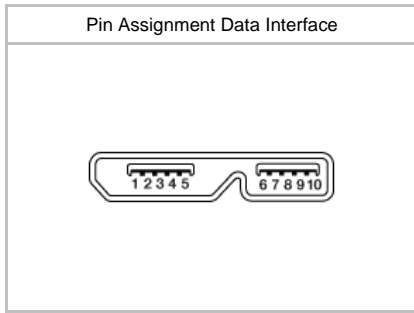

## Interfaces and Connectors

Process Interface	Connector:	M8/8-pin (SACC-DSI-M8MS-8CON-M8-L180)
	Assignment:	1 - GPIO (Line2)    2 - not connected 3 - IN1 (Line0)    4 - GND IN1 5 - Power VCC    6 - OUT1 (Line3) OUT1    8 - GPIO (Line1) 7 - GND GPIO

Caution



\* Note GPIOs: Ground loops are to be avoided and can lead to destruction of the device.

## Optical Data

Lens Mount	C-Mount
Optical Filter	IR cut filter

## Mechanical Data

Housing	Zinc die casting, baked varnish
Protection Class	IP40 (with mounted lens and USB 3.0 cable)
Weight	90 g
Dimensions	

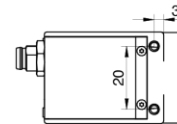
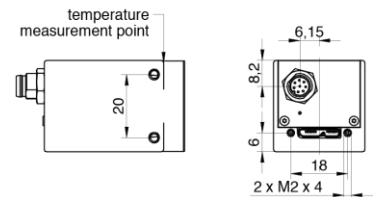
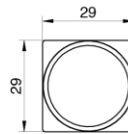
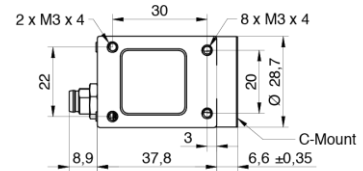

## Environmental Data

Storage Temperature	-20 °C ... + 70 °C
Operating Temperature	0 °C ... +60 °C @ T = Measurement Point or 0 °C ... +75 °C @ internal Temperature Sensor Note: Ambient temperature above 30 °C requires heat dissipation measures.
Int. Temperature Sensor	yes, accuracy: ±1 °C (typ) 0 °C ... +85 °C
Humidity	10 % ... 90 % non-condensing

<sup>1)</sup> the maximum temperature for Sony sensor characteristics (sensor performance) are guaranteed up to 47 °C @ Measurement Point or up to 58 °C @ internal temperature sensor

## LED Signalling

LED	Green flash	Power on, no link active
	Green	Link active USB 3.0
	Red	Error or Link active USB 2.0
	Yellow	Sensor Readout activity
	Red flash	Update

## Electrical Data

Power Supply	bus powered via USB3.0 interface
Power Consumption	approx. 3.1 W @ 31 fps (Factory Setting "Default")
Digital Input	Optocoupler $U_{IN(low)}$ : 0.0 ... 4.5 VDC $U_{IN(high)}$ : 11.0 ... 30.0 VDC $I_{IN}$ : 3.0 ... 10.0 mA min. Impulse Length: 2.0 $\mu$ sec
Digital Output	Optocoupler $U_{EXT}$ : 5 ... 30 V DC $I_{OUT}$ : max. 50 mA $t_{ON}$ = typ. 3 $\mu$ sec $t_{OFF}$ = typ. 40 $\mu$ sec
GPIO	direct, without optocoupler
GPIO used as Input:	$U_{IN(low)}$ : 0.0 ... 0.8 VDC $U_{IN(high)}$ : 2.0 ... 30.0 VDC min. Impulse Length: 2.0 $\mu$ sec
GPIO used as Output:	$U_{Out(low)}$ : 0.0 ... 0.4 VDC ( $I_{sink\ max}$ : 50 mA) $U_{Out(high)}$ : 2.4 ... 3.3VDC ( $I_{max}$ : 1 mA)
Caution 	* The General Purpose I/Os (GPIOs) are not potential-free and do not have an overrun cut-off. Incorrect wiring (overvoltage, undervoltage or voltage reversal) can lead to defects in the electronic system. Ground loops are to be avoided and can lead to destruction of the device.

## Conformity

Conformity	CE, RoHS, REACH
KC Registration No. / Date	- / -
MTBF	50 years @ T = 45 °C / 32 years @ T = 60 °C T = Measurement Point

## GeniCam™ Features

Short Exposure Range	yes, ShortExposureTimeEnable Short Exposure Range 1 ... 3 $\mu$ sec - 15 $\mu$ sec ... 60 sec Default Exposure Range 15 $\mu$ sec ... 60 sec
Timer	Timer Selector: Timer Selector: Timer 1 TimerTriggerSource: Line0, SoftwareTrigger, ExposureStart, ExposureEnd, FrameTransferSkipped, TriggerSkipped, Off TimerDelay: 0 $\mu$ sec ... 2 sec, Step Size: 1 $\mu$ sec TimerDuration: 4 $\mu$ sec ... 2 sec, Step Size: 1 $\mu$ sec
Counter	Counter Selector: Counter 1, Counter 2 CounterValue: 0 ... 65535 Counter Event Source: Counter1End or Counter2End, ExposureActive, FrameTransferSkipped, FrameTrigger, TriggerSkipped, Line0..2 and Off Counter Reset Source: Counter1End, Counter2End, Line0..2 and Off
Sequencer	Sequencer Characteristics: up to 128 sets, up to 4 possible pathes for triggered set transitions, 6 trigger sources: Counter1End, Counter2End, ExposureActive, Line0..2, ReadoutActive, Timer1End Sequencer Parameters for Exposure, Gain, Trigger, ROI and Output: ExposureTime, CounterDuration, CounterEventActivation, CounterEventSource, CounterResetSource, ExposureMode, ExposureTime, Gain, Height, OffsetX, OffsetY, TriggerMode, UserOutputValue, UserOutputValueAll, Width

## GenICam™ Features

User Sets	Factory Settings: UserSet0 (read only) Freely Programmable: UserSet1, UserSet2, UserSet3 Parameters: any user definable Parameter
Acquisition Abort	Delay up to 39.1 msec
Chunk Data	yes, Chunk Selector: Binning, BlackLevel, CounterValue, DeviceTemperature, ExposureTime, FrameID, Gain, Height, Image, ImageControl, LineStatusAll, OffsetX, OffsetY, PixelFormat, SequencerSetActive, Timestamp, Width
Device Temperature	InHouse Event generation for Normal to High, High to Exceeded and Exceeded to Normal Exceeded (no image transfer) = max. internal temperature sensor + 1 °C
Device Link Throughput Limit	yes, up to max. Device Link Speed
Custom Data	yes, 128 Byte with CustomDataKonfiguration Mode
Calibration Data	yes, camera calibration values can stored: CalibrationMatrix, CalibrationMatrixNew, CalibrationFocalLenght, CalibrationAngularAperture, GeometryDistortionValue: k1, k2, p1, p2, k3, CalibrationVector: tvec, rvec and CalibrationDataVersion
SFNC Version	2.4.0

## Factory Settings after Start-Up

Trigger Mode	Off (Free Running)
Analog Controls	Exposure Time: 4 msec, Gain: 0 dB, Offset: 0
Pixel Format	BayerRG8
Partial Scan	Off
Acquisition Frame Rate	Off
Timer/Counter/Sequencer	Off
Defect Pixel Correction	ON
Fixed Pattern Noise Correction	-
Digital Input	Line0, invert = false
Digital Output	Line3, invert = false, line source = Off
GPIO 1/2	Line1, Line2, invert = false, LineMode = Input
TriggerSource	All

**Partial Scan** @ FullFrame, min Exposure, Mono8 (monochrome camera) or BayerRG8 (color camera)

	Resolution	max. fps acquisition	max. fps interface <sup>2)</sup>
UHD (4K)	3840 x 2160	42	42
Full HD	1920 x 1080	80	80
SXGA	1280 x 1024	84	84
HD720	1280 x 720	114	114
XGA	1024 x 768	108	108
SVGA	800 x 600	133	133
VGA	640 x 480	159	159
CIF	352 x 288	231	231
QVGA	320 x 240	260	260
QCIF	176 x 144	349	349
LineScan	4096 x 2048	45	45
	4096 x 1024	84	84
	4096 x 512	151	151
	4096 x 256	250	250
	4096 x 128	370	370
	4096 x 64	488	488
	4096 x 32	580	580
	4096 x 16	640	640
	4096 x 8	675	675
	4096 x 4	675	675
	4096 x 2	675	675
	4096 x 1	-	-

<sup>2)</sup> depends on the used interface