



Quick Start Guide
 VLXT(.I) (.EF) (.JP) cameras (10 Gigabit Ethernet)
 VLXN.I cameras (5 Gigabit Ethernet)

Download latest camera software:
www.baumer.com/vision/software

Download latest technical documentation:
www.baumer.com/cameras/docs

Product Specification

VLXT cameras – Extremely functionality and high frame rates

- GigE Vision™ standard compliant
- Optional: Protection classes IP67 (with installed tube)
- Optional: Modular tube system
- M12 industry connectors
- PWM on outputs for direct controlled illuminations
- 4 outputs with maximum 1.5 A (2.5 A with 40% periode time)

Notice
 Further technical details are available in the respective data sheets.

Dimensions (TFL-mount)

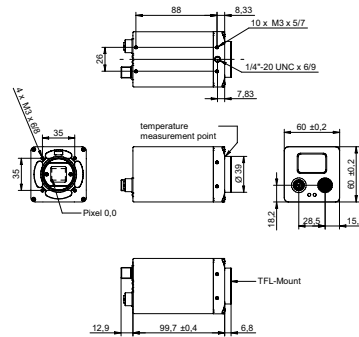

Dimensions (EF-mount)

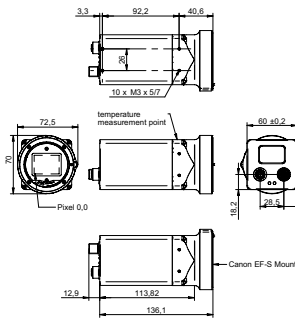

System Requirements

	Recommended for GigE	Recommended for 10 GigE
CPU	Intel® Core™ i5-2520M CPU @ 2.50 GHz, Cores: 4	Intel® Core™ i7-3770 CPU @ 3.40 GHz, Cores: 8
RAM	4 GB	8 GB
Operating system (OS)	Microsoft® Windows® 7 (32 / 64 bit systems) Microsoft® Windows® 8 (32 / 64 bit systems)	Microsoft® Windows® 10 (32 / 64 bit systems)

Dimensions (C-mount)

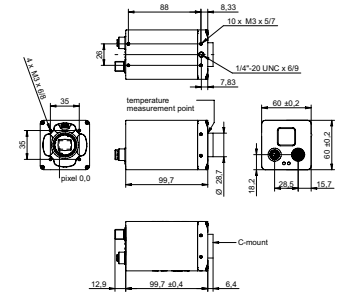

Dimensions (M58-mount)

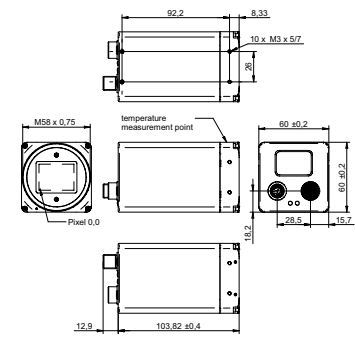

Installation

Lens mount

Notice
 Ensure the sensor and lens are not contaminated with dust and airborne particles when mounting the support or the lens to the device!

The following points are very important:

- Install the camera in an environment that is as dust free as possible!
- Keep the dust cover (bag) on the camera for as long as possible!
- Hold the camera with the sensor downwards if the sensor is uncovered.
- Avoid contact with any of the camera's optical surfaces!

Modular tube system (ordered separately)

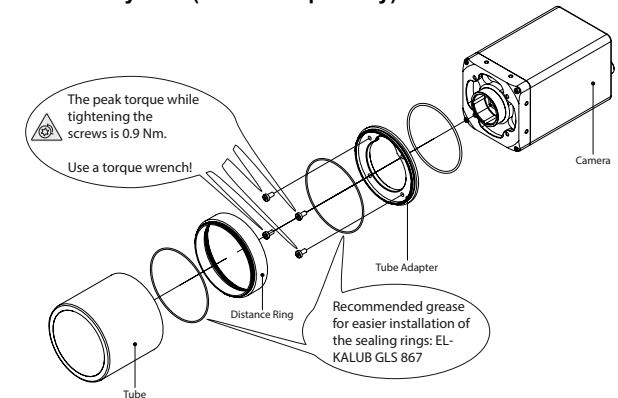

Conformity / Safety

Conformity

CE
 We declare, under our sole responsibility, that the previously described Baumer VLXT cameras conform with the directives of the CE.



Several of the described Baumer cameras conform with the directives of the Korean Conformity.



The camera has been tested by UL (Underwriters Laboratories) and complies with the requirements of the standards.

Please see the User's Guide for further information.

Further Information
 For further information on our products visit www.baumer.com
 For technical issues, please contact our technical support:
support_cameras@baumer.com · Phone +49 (0)3528 4386-0 · Fax +49 (0)3528 4386-86
 © Baumer Optronik GmbH · Badstrasse 30 · DE-01454 Radeberg, Germany

Technical data has been fully checked, but accuracy of printed matter not guaranteed.

Subject to change without notice. Printed in Germany 09/24. v10 11207581



General Description

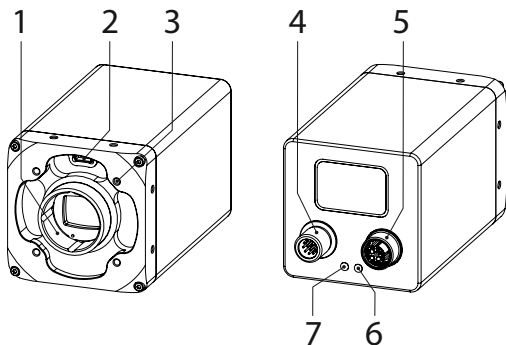

No.	Description	No.	Description
1	Lens mount (C- / M58- / TFL- / EF-mount)	5	Ethernet port
2	UART0 Interface (≥ Release 3, C- / EF-Mount only)	6	Camera LED
3	4 x Tube Adapter /front mounting threads (except M58-, EF-mount)	7	GigE LED
4	Power- and process interface (including UART1 / RS232)		

Data Interface / Digital IOs

Ethernet (SACC-CI-M12FS-8CON-L180-10G)



1	MX1+	5	MX4+
2	MX1-	6	MX4-
3	MX2+	7	MX3-
4	MX2-	8	MX3+

Power supply / Digital IOs (on camera side) (SACC-CI-M12MS-12CON-L180)

M12 / 12 pins / wire colors of the connecting cable (ordered separately)



1	Power V _{CC}	brown	7	OUT3 (Line6)	black
2	GND (Power)	blue	8	RS232 Txd (Line2)	grey
3	IN1 (Line0)	white	9	OUT4 (Line7)	red
4	OUT1 (Line4)	green	10	RS232 RxD (Line3)	violet
5	IN2 (Line1)	pink	11	GND (IO)	grey-pink
6	OUT2 (Line5)	yellow	12	Power (IO)	red-blue

LED Signaling

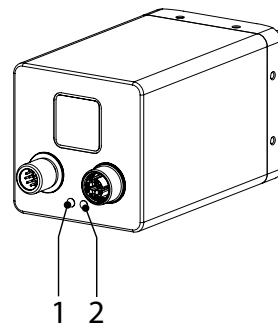

LED	Signal	Meaning
1	green static	link active
	green flash	receiving
2	yellow static	camera error
	yellow flash	transmitting

Power Supply

Power Supply

Power V _{CC}	24 V (± 20 %) / Power consumption: max. 15.5 W
	<u>For UL conform installation:</u> Class 2 per NEC / Protection Class III The device is intended to be supplied from an isolated Limited Energy Source per UL61010-1, 3rd ed cl. 9.4 or Limited Power Source per UL60950-1 or Class 2 per NEC.

⚠ Caution

In order to achieve the mentioned IP protection level, the M12 connectors need to be tightened with a torque value of 0.4 Nm.



For that Baumer suggests the use of a torque driver (such as Wiha TorqueVario®-S ESD) in combination with a wrench for assembling sensor/ actuator cables with M12 connector (such as Phoenix Contact SAC BIT M12-D15).

Heat Transmission

⚠ Caution

Heat can damage the camera. Ambient temperature above 25 °C (77 °F) requires heat dissipation measures. Provide adequate dissipation of heat, to ensure that the temperatures does not exceed the specified values. Baumer recommends the following methods for proper heat dissipation:



- Every form of convection around the device and mounting helps reduce temperature. Prevent heat from becoming trapped!
- Mounting in combination with forced convection may provide proper heat dissipation.
- Avoid mounting onto stainless steel. Stainless steel has a roughly 10-fold lower thermal conductivity compared to aluminium.
- Do not install the device at the end of a profile; this will allow heat to dissipate on both sides (higher temperature drops over a larger area)!
- Do not operate other devices in close proximity to the camera. Their waste heat could additionally heat the camera.
- From an ambient temperature of 30 °C (86 °C) up to +40 °C (104 °F) the camera requires forced air cooling (min. 0.9 m/s).

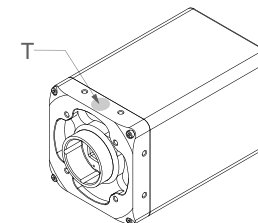

See User's Guide for further information.

Installation

Installation of the camera:

- Connect the camera using an appropriate cable (at least Cat-5e) to the GigE board on your PC.
- If required, connect a trigger and / or flash to process interface.
- Connect the camera to power supply.

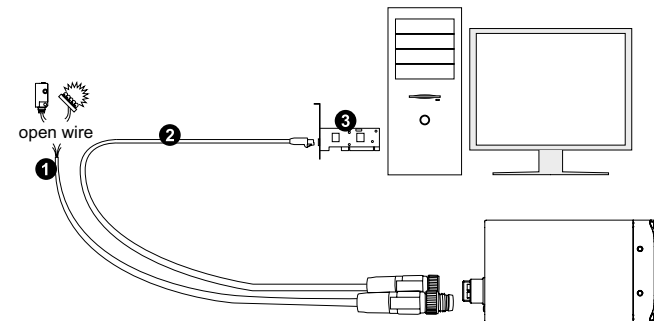

Installation sample

- 1 - Cable for trigger and flash
- 2 - GigE cable
- 3 - PCI board