

## PMG10 - DeviceNet

Solid shaft  $\varnothing 11$  mm with EURO flange B10 or housing foot B3

DeviceNet / 13 bit ST / 16 bit MT / Speed switch

### Overview

- Interface DeviceNet
- Magnetic sensing method
- Resolution: singleturn 13 bit, multiturn 16 bit
- Function display via LEDs
- Multiturn sensing with Energy Harvesting technology "MicroGen", without gear or battery
- Two-sided bearing system with hybrid bearings
- Special protection against corrosion CX (C5-M)



Picture similar

**HUBNER**  
BERLIN  
A Baumer Brand

**microGen**  
Energy Harvesting

### Technical data

#### Technical data - electrical ratings

Voltage supply	10...30 VDC
Short-circuit proof	Yes
Consumption w/o load	$\leq 200$ mA
Initializing time	$\leq 500$ ms after power on
Interface	DeviceNet
Function	Multiturn
Transmission rate	125 ... 500 kBaud
Device address	Rotary switches in bus connecting box
Steps per revolution	8192 / 13 bit
Number of revolutions	65536 / 16 bit
Additional outputs	Square-wave TTL/HTL, TTL/RS422
Sensing method	Magnetic
Interference immunity	EN 61000-6-2
Emitted interference	EN 61000-6-3
Programmable parameters	Steps per revolution Number of revolutions Preset, scaling, rotating direction
Diagnostic function	Position or parameter error
Status indicator	DUO-LED (bus connecting box) 4 LEDs in device back side
Approval	CE UL approval / E217823

#### Technical data - electrical ratings (speed switch)

Switching accuracy	$\pm 2$ % (or 1 Digit)
Switching outputs	1 output (Open collector, solid state relay on request)
Output switching capacity	30 VDC; $\leq 100$ mA

### Optional

- Integrated speed switch
- Additional output incremental with zero pulse

#### Technical data - electrical ratings (speed switch)

Switching delay time	$\leq 20$ ms
----------------------	--------------

#### Technical data - mechanical design

Size (flange)	$\varnothing 115$ mm
Shaft type	$\varnothing 11$ mm solid shaft
Flange	EURO flange B10 Housing foot B3
Protection EN 60529	IP 66 / IP 67
Operating speed	$\leq 6000$ rpm
Range of switching speed	ns (off) = $\pm 2$ ...6000 rpm
Operating torque typ.	10 Ncm
Rotor moment of inertia	1 kgcm <sup>2</sup>
Admitted shaft load	$\leq 450$ N axial $\leq 650$ N radial
Material	Housing: aluminium alloy Shaft: stainless steel
Corrosion protection	IEC 60068-2-52 Salt mist for ambient conditions CX (C5-M) according to ISO 12944-2
Operating temperature	-40...+85 °C
Relative humidity	95 % non-condensing
Resistance	IEC 60068-2-6 Vibration 30 g, 10-2000 Hz IEC 60068-2-27 Shock 400 g, 1 ms
Weight approx.	2.7 kg (depending on version)
Connection	Bus connecting box Terminal box incremental

# PMG10 - DeviceNet

Solid shaft  $\varnothing 11$  mm with EURO flange B10 or housing foot B3

DeviceNet / 13 bit ST / 16 bit MT / Speed switch

## Terminal assignment

### DeviceNet - View A (see dimension)

View inside bus connecting box DeviceNet

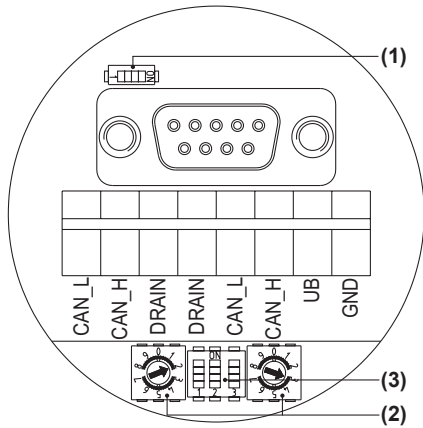

Terminals of the same significance are internally connected and identical in their functions. Max. load on the internal terminal connections UB-UB and GND-GND is 1 A each.

### Terminating resistor (1)

ON = Last user

OFF = User x

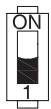

### User address (2)

Defined by rotary switch.

Example: User address 23

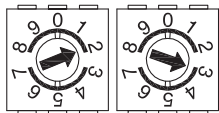

### DeviceNet - Transmission rate (3)

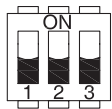

Transmission rate	Setting DIP switches		
	1	2	3
125 kBaud*	X	OFF	OFF
250 kBaud	X	OFF	ON
500 kBaud	X	ON	OFF
125 kBaud	X	ON	ON

X = Without function

\* Factory setting

## Terminal assignment

### View A1 and A2 (see dimension)

View into connector DeviceNet

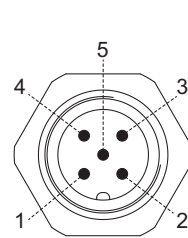

Connector M12 (male, A1)  
5-pin, A-coded

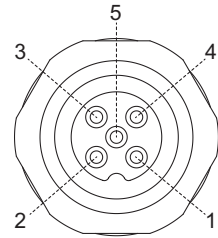

Connector M12 (female, A2)  
5-pin, A-coded

Pin	Connection
1	DRAIN
2	UB
3	GND
4	CAN_H
5	CAN_L

Terminals of the same significance are internally connected and identical in their functions. Max. load on the internal terminal connections GND-GND is 1 A each.

### View B (see dimension)

Connecting terminal terminal box

Speed switch /

additional output II (HTL, TTL)

\* Assignment depends on encoder version

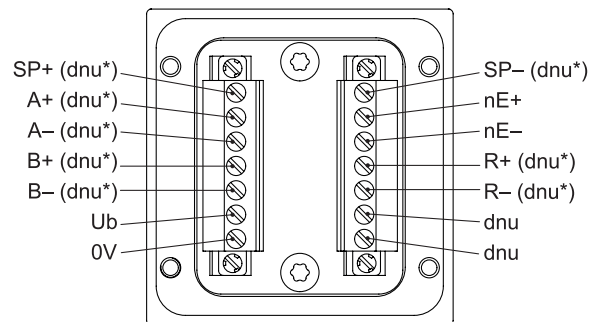

## Terminal significance

### DeviceNet

Connection	Description
GND	Ground for UB
UB	Voltage supply 10...30 VDC
CAN_H	CAN Bus signal (dominant HIGH)
CAN_L	CAN Bus signal (dominant LOW)
DRAIN	Shield connection

# PMG10 - DeviceNet

Solid shaft  $\varnothing 11$  mm with EURO flange B10 or housing foot B3

DeviceNet / 13 bit ST / 16 bit MT / Speed switch

## Terminal significance

Ub	Voltage supply
0V	Ground
A+	Output signal channel 1
A-	Output signal channel 1 inverted
B+	Output signal channel 2 (offset by 90° to channel 1)
B-	Output signal channel 2 inverted
R+	Zero pulse (reference signal)
R-	Zero pulse inverted
nE+	System OK+ / error output
nE-	System OK- / error output inverted
SP+	DSL_OUT1 / speed switch (open collector, solid state relay on request)
SP-	DSL_OUT2 / speed switch (0V, solid state relay on request)
dnu	Do not use

## DeviceNet features

Bus protocol	DeviceNet
Device profile	Device Profil for Encoders V 1.0
Operating modes	<ul style="list-style-type: none"> <li>■ I/O-Polling</li> <li>■ Cyclic</li> <li>■ Change of State</li> </ul>
Preset value	The „Preset“ parameter can be used to set the encoder to a predefined value that corresponds to a specific axis position of the system. The offset of encoder zero point and mechanical zero point is stored in the encoder.
Parameter functions	<p>Rotating direction: The relationship between the rotating direction and rising or falling output code values can be set in the operating parameter.</p> <p>Scaling: The parameter values set the number of steps per turn and the overall resolution.</p>
Diagnostic	<p>The encoder supports the following error warnings:</p> <ul style="list-style-type: none"> <li>■ Position and parameter error</li> </ul>
Factory setting	User address 00

## Output signals

### Additional output II (HTL/TTL)

At positive rotating direction (see dimension)

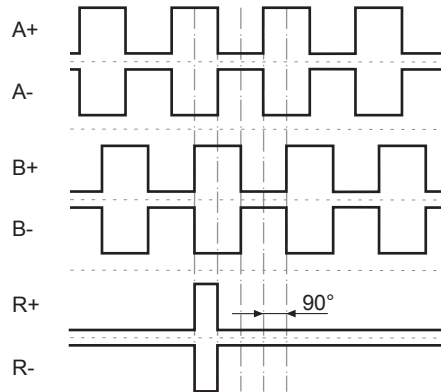

## Trigger level

### Incremental HTL/TTL

Electrically isolated:

The output TTL/HTL ( $V_{in} = V_{out}$ ) at the additional output II is electrically isolated and requires a separate power supply.

Trigger level	TTL/RS422
High / Low	$\geq 2.5$ V / $\leq 0.5$ V
Transmission length	$\leq 550$ m @ 100 kHz
Output frequency	$\leq 600$ kHz
Trigger level	TTL/HTL ( $V_{in} = V_{out}$ )
High / Low	$\geq 2.5$ V / $\leq 0.5$ V (TTL) $\geq U_b - 3$ V / $\leq 1.5$ V (HTL)
Transmission length	$\leq 550$ m @ 100 kHz (TTL) $\leq 350$ m @ 100 kHz (HTL)
Output frequency	$\leq 600$ kHz (TTL); $\leq 350$ kHz (HTL)

# PMG10 - DeviceNet

Solid shaft  $\varnothing 11$  mm with EURO flange B10 or housing foot B3  
DeviceNet / 13 bit ST / 16 bit MT / Speed switch

## Switching characteristics

### Speed switch

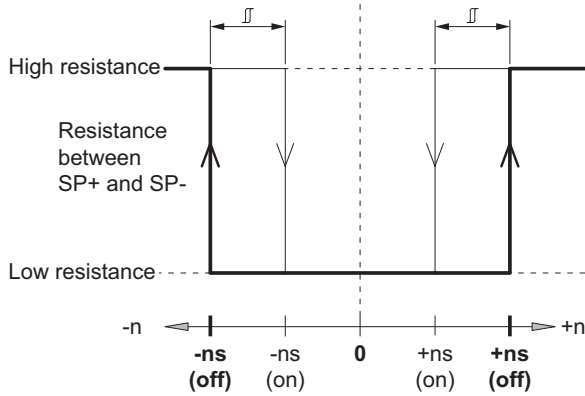

n	Speed
<b>+ns (off)</b>	Switch-off speed at shaft rotation in positive rotating direction ( <i>see dimension</i> ).
<b>-ns (off)</b>	Switch-off speed at shaft rotation in negative rotating direction ( <i>see dimension</i> ).
	Switching hysteresis $\Delta$ : 10...100 % (factory setting = 10 % min. 1 Digit)
<b>+ns (on)</b>	Switch-on speed at shaft rotation in positive rotating direction ( <i>see dimension</i> ).
<b>-ns (on)</b>	Switch-on speed at shaft rotation in negative rotating direction ( <i>see dimension</i> ).

# PMG10 - DeviceNet

Solid shaft  $\varnothing 11$  mm with EURO flange B10 or housing foot B3

DeviceNet / 13 bit ST / 16 bit MT / Speed switch

## Dimensions

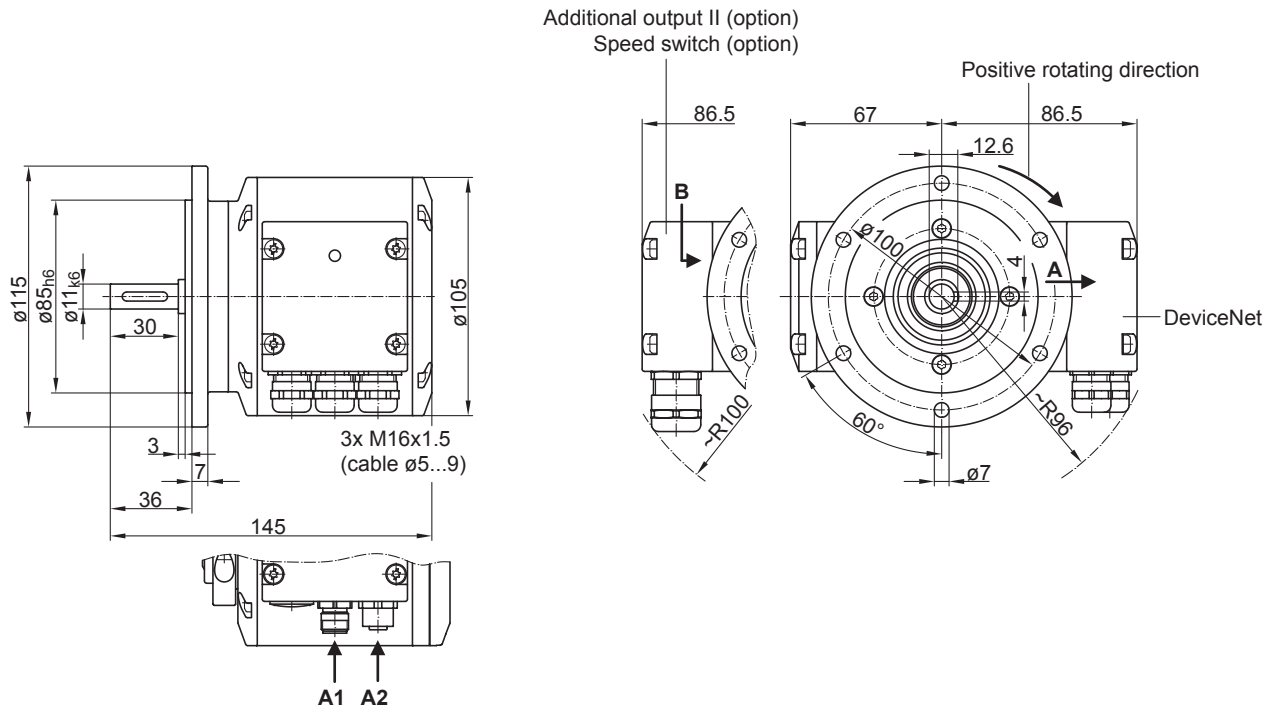

### Version with Euro flange (B10)

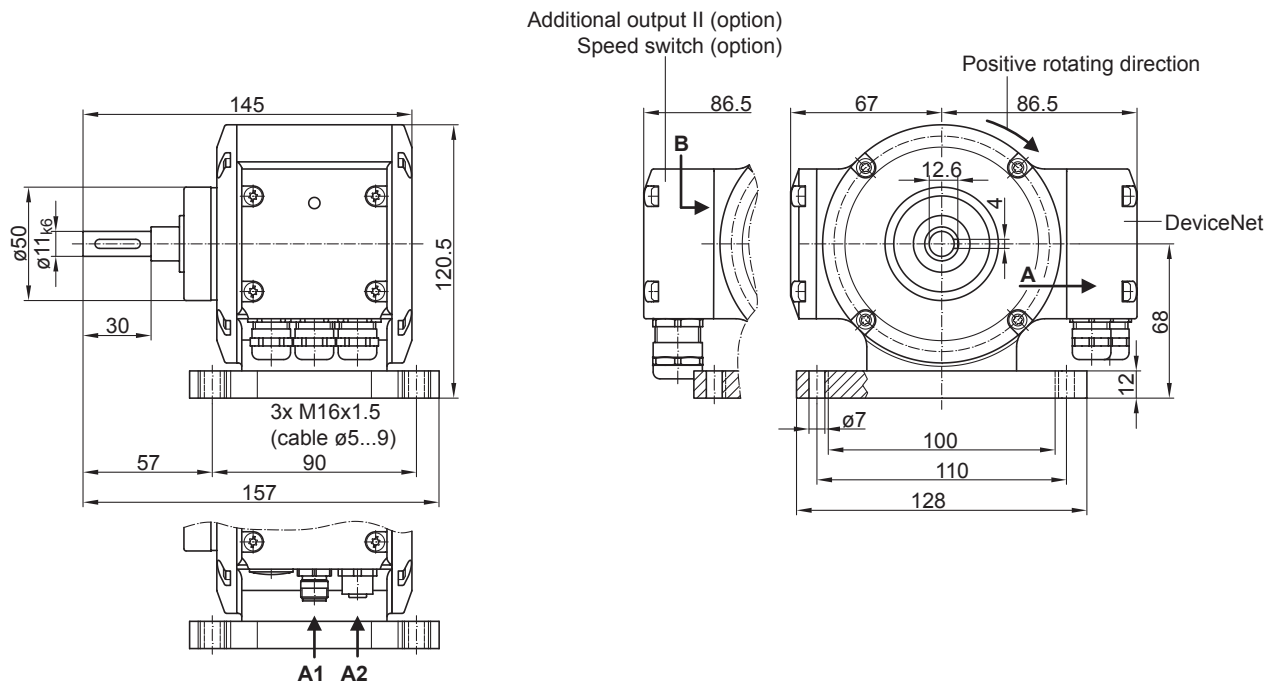

### Version with housing foot (B3)

# PMG10 - DeviceNet

Solid shaft ø11 mm with EURO flange B10 or housing foot B3

DeviceNet / 13 bit ST / 16 bit MT / Speed switch

**Ordering reference**

	PMG10	#	-	S	H	#	.	1	#	DN	3	.	#	0	0	#	A
<b>Product</b>	PMG10																
Absolute encoder	PMG10																
<b>Digital speed switch</b>																	
With <sup>(1)</sup>				D													
Without				-													
<b>Shaft type</b>					S												
Solid shaft					S												
<b>Flange (Solid shaft)</b>						H											
EURO flange B10, hybrid bearings						H											
<b>Protection class</b>																	
IP 66 and IP 67, optimized for dusty, abrasive environment										D							
IP 66 and IP 67, optimized for oily, wet environment										L							
<b>Solid shaft</b>																	
ø11 mm, featherkey 4 mm											1						
<b>Connection</b>																	
Bus connecting box with 3 cable glands M16, radial																	5
Bus connecting box with 2 connectors M12, radial																	1
Bus connecting box with 3 cable glands M16, radial + terminal box with 1 cable gland M20, radial																	F
Bus connecting box with 2 connectors M12, radial + terminal box with 1 cable gland M20, radial																	Z
<b>Supply voltage (field bus)</b>																	
10...30 VDC, DeviceNet																	DN
<b>Resolution singleturn position</b>																	
13 Bit																	3
<b>Resolution multiturn position</b>																	
No multiturn signal																	0
16 Bit																	6
<b>Resolution speed</b>																	
No speed signal																	0
<b>Resolution supplement I</b>																	
No additional output I																	0
<b>Resolution supplement II</b>																	
No additional output II																	0
8192 ppr TTL/HTL push-pull (Vin=Vout), 6 channels, electrically isolated																	Q
8192 ppr TTL (RS422), 6 channels																	P
5000 ppr TTL/HTL push-pull (Vin=Vout), 6 channels, electrically isolated																	G
5000 ppr TTL (RS422), 6 channels																	H
4096 ppr TTL/HTL push-pull (Vin=Vout), 6 channels, electrically isolated																	K
4096 ppr TTL (RS422), 6 channels																	J
3072 ppr TTL/HTL push-pull (Vin=Vout), 6 channels, electrically isolated																	7
3072 ppr TTL (RS422), 6 channels																	8
2048 ppr TTL/HTL push-pull (Vin=Vout), 6 channels, electrically isolated																	9
2048 ppr TTL (RS422), 6 channels																	4
1024 ppr TTL/HTL push-pull (Vin=Vout), 6 channels, electrically isolated																	5
1024 ppr TTL (RS422), 6 channels																	6
512 ppr TTL/HTL push-pull (Vin=Vout), 6 channels, electrically isolated																	1
512 ppr TTL (RS422), 6 channels																	2
<b>Operating temperature</b>																	
-40...+85 °C																	A

(1) Please specify the exact switching speed in addition to the part number (factory setting).

## PMG10 - DeviceNet

Solid shaft  $\varnothing 11$  mm with EURO flange B10 or housing foot B3

DeviceNet / 13 bit ST / 16 bit MT / Speed switch

### Ordering reference

It may happen that not all variants of the type code can be combined. Any restrictions can be found in the web configurator at [www.baumer.com](http://www.baumer.com) or on request.

### Accessories

#### Mounting accessories

	Spring disk coupling K 50 (shaft $\varnothing 11 \dots 16$ mm)
11064874	Spring disk coupling K60 WD 11PF4 + 12PF4