

# PF75S (remote, one electrical connection)

Electromagnetic flow meter for industrial applications

PF75S-5#####1##3#####A#00#0

## Overview

- Volume and velocity measurements in one sensor
- Precise and stable measurements with accuracies to 0.2%
- For media with conductivity > 5 µS/cm in closed systems
- Measurement range 0 ... 4500 m³/h with pipe diameter DN 3 ... 400
- Robust and resistant to temperature jumps
- No energy loss thanks to continuous measuring tube without constriction
- Graphic display CombiView DFON optionally available and programmable via touch screen or BCP software



Picture similar

## Technical data

### Performance characteristics

Measuring principle	Electromagnetic flow measurement
Nominal diameter range	DN 3 ... DN 400
Max. flow velocity	10 m/s
Max. measuring error	± 1.0 % o. r. ± 0.5 % o. r. , optional ± 0.2 % o. r. , optional
Max. turndown ratio	1 : 1000
Measuring range, flow	0 ... 10 m/s 0 ... 4500 m³/h
Media characteristics	≥ 5 µS/cm
Step response time	≤ 400 ms
Sampling interval	≤ 200 ms
Min. measuring span	0 ... 0.01 m³/h
Damping	0.2 ... 1000 s
Repeatability	≤ 0.1 % o. r.

### Process conditions

Process temperature	According to the configuration
Process pressure	According to the configuration

### Process connection

Connection variants	EN 1092-1 ASME (ANSI) B 16.5 / EN 1759-1 Class 150 DIN 228-1 male thread NPT male thread
Sensor tube dimensions	According to the configuration DN 3 ... DN 400 3 ... 400 mm
Sensor tube material	Painted steel AISI 316L (1.4404) AISI 304 (1.4301)
Wetted parts material, process connection	AISI 316L (1.4404) AISI 304 (1.4301)
Wetted parts material, liner	According to the configuration
Wetted parts material, electrodes	According to the configuration

### Process connection

Wetted parts material, gasket	According to the configuration
-------------------------------	--------------------------------

### Surface roughness (in contact with medium)

Process connection	Ra ≤ 0.8 µm
--------------------	-------------

### Ambient conditions

Operating temperature range	-20 ... 80 °C , with DFON touch screen -20 ... 85 °C , without DFON touch screen
Optimal readability temperature range	-10 ... 70 °C
Storage temperature range	-20 ... 60 °C
Altitude	-200 ... 4000 m
Degree of protection (EN 60529)	IP 65 IP 67
Humidity	0 ... 100 %
Insulation resistance	> 100 MΩ
Insulation voltage	500 V DC

### Output signal

Digital output signal	1 x pulse / frequency / alarm 2 x pulse / frequency / alarm (optional)
Analog output (optional)	0...20 mA 4...20 mA
Voltage drop	1.2 V DC
Relays	2 relays included in the display
Load resistance	≤ 500 Ω, Vs = 18 V DC ≤ 1000 Ω, Vs = 30 V DC
Short circuit protection	Yes
Reverse polarity protection	Yes
Damping	0.2 ... 1000 s

### Housing

Style	Split version, without mounting kit FlexHousing, Ø80 mm Bottom process connection
Overall size	Refer to section "Dimensional drawings"
Material	AISI 304 (1.4301)

# PF75S (remote, one electrical connection)

Electromagnetic flow meter for industrial applications

PF75S-5#####1##3#####A#00#0

## Technical data

### Electrical connection

Connector M12-A, 5-pin, stainless steel

### Power supply

Voltage supply range 18 ... 30 V DC

Power consumption ≤ 5 W

 Power-up time ≤ 30 s , standard use  
 ≤ 15 min , warm-up for calibration

### Power supply

Reverse polarity protection Yes

### Compliance and approvals

 EMC IEC 61326-1  
 EN 61326-1

## Operating conditions

Nominal diameter	Min. measuring span		Max. measuring span	
DN3	0 ... 0.01 m <sup>3</sup> /h	0 ... 2.6 gal/h	0 ... 0.25 m <sup>3</sup> /h	0 ... 66 gal/h
DN6	0 ... 0.04 m <sup>3</sup> /h	0 ... 10.6 gal/h	0 ... 1.0 m <sup>3</sup> /h	0 ... 264 gal/h
DN10	0 ... 0.11 m <sup>3</sup> /h	0 ... 29.1 gal/h	0 ... 2.8 m <sup>3</sup> /h	0 ... 740 gal/h
DN15	0 ... 0.25 m <sup>3</sup> /h	0 ... 66.0 gal/h	0 ... 6 m <sup>3</sup> /h	0 ... 1585 gal/h
DN20	0 ... 0.45 m <sup>3</sup> /h	0 ... 118.9 gal/h	0 ... 11 m <sup>3</sup> /h	0 ... 2906 gal/h
DN25	0 ... 0.72 m <sup>3</sup> /h	0 ... 190.2 gal/h	0 ... 18 m <sup>3</sup> /h	0 ... 4755 gal/h
DN32	0 ... 1.16 m <sup>3</sup> /h	0 ... 306.4 gal/h	0 ... 29 m <sup>3</sup> /h	0 ... 7660 gal/h
DN40	0 ... 1.8 m <sup>3</sup> /h	0 ... 475.5 gal/h	0 ... 45 m <sup>3</sup> /h	0 ... 11887 gal/h
DN50	0 ... 2.88 m <sup>3</sup> /h	0 ... 760.8 gal/h	0 ... 72 m <sup>3</sup> /h	0 ... 19020 gal/h
DN65	0 ... 4.8 m <sup>3</sup> /h	0 ... 1268.0 gal/h	0 ... 120 m <sup>3</sup> /h	0 ... 31700 gal/h
DN80	0 ... 7.2 m <sup>3</sup> /h	0 ... 1902.0 gal/h	0 ... 180 m <sup>3</sup> /h	0 ... 47550 gal/h
DN100	0 ... 11.2 m <sup>3</sup> /h	0 ... 2958.7 gal/h	0 ... 280 m <sup>3</sup> /h	0 ... 73968 gal/h
DN125	0 ... 18.0 m <sup>3</sup> /h	0 ... 4755.0 gal/h	0 ... 450 m <sup>3</sup> /h	0 ... 118877 gal/h
DN150	0 ... 25.6 m <sup>3</sup> /h	0 ... 6762.8 gal/h	0 ... 640 m <sup>3</sup> /h	0 ... 169070 gal/h
DN200	0 ... 45.2 m <sup>3</sup> /h	0 ... 11940.6 gal/h	0 ... 1130 m <sup>3</sup> /h	0 ... 298514 gal/h
DN250	0 ... 70.8 m <sup>3</sup> /h	0 ... 18703.4 gal/h	0 ... 1770 m <sup>3</sup> /h	0 ... 467584 gal/h
DN300	0 ... 100.8 m <sup>3</sup> /h	0 ... 26628.5 gal/h	0 ... 2520 m <sup>3</sup> /h	0 ... 665714 gal/h
DN350	0 ... 138.0 m <sup>3</sup> /h	0 ... 36455.7 gal/h	0 ... 3450 m <sup>3</sup> /h	0 ... 911394 gal/h
DN400	0 ... 180.0 m <sup>3</sup> /h	0 ... 47551.0 gal/h	0 ... 4500 m <sup>3</sup> /h	0 ... 1188774 gal/h

Note: gal is defined as US liq. gal.

## Display

### General information

Panel type FSTN Graphical LCD

Display range -9999 ... 99999

Max. digit height 22 mm

Material Polycarbonate

### Ambient conditions

Operating temperature range -20 ... 80 °C

Optimal readability temperature range -10 ... 70 °C

### Input signal

 Update time ≤ 1 s , max.  
 0.3 s , typ.

### User configurable data

Error- / Warning-indication Individually configurable display and backlight indication in white, green or red colour, steady or flashing light. Configurable limits over the range

 Measuring unit  
 μS/cm  
 mS/cm  
 %  
 °C  
 °F  
 cm/s  
 Hz  
 kHz  
 l/h  
 m/s  
 m<sup>3</sup>/h

User defined measuring unit 8 × 20 pixel matrix

### Relays

Contacts 2 x solid state relays

Max. load current 75 mA

Max. switching voltage 60 V

## PF75S (remote, one electrical connection)

Electromagnetic flow meter for industrial applications

PF75S-5#####1##3#####A#00#0

### Dimensional drawings (mm)

Nominal diameter	Process connection	Nominal pressure	D	H	L
DN3	EN 1092-1	PN16	90 mm	128 mm	200 mm
DN6	EN 1092-1	PN16	90 mm	128 mm	200 mm
DN10	EN 1092-1	PN16	90 mm	128 mm	200 mm
DN15	EN 1092-1	PN16	95 mm	130 mm	200 mm
DN20	EN 1092-1	PN16	105 mm	135 mm	200 mm
DN25	EN 1092-1	PN16	115 mm	181 mm	200 mm
DN32	EN 1092-1	PN16	140 mm	187 mm	200 mm
DN40	EN 1092-1	PN16	150 mm	197 mm	200 mm
DN50	EN 1092-1	PN16	165 mm	211 mm	200 mm
DN65	EN 1092-1	PN16	185 mm	231 mm	200 mm
DN80	EN 1092-1	PN16	200 mm	241 mm	200 mm
DN100	EN 1092-1	PN16	220 mm	267 mm	250 mm
DN125	EN 1092-1	PN16	250 mm	267 mm	250 mm
DN150	EN 1092-1	PN16	285 mm	321 mm	300 mm
DN200	EN 1092-1	PN16	340 mm	379 mm	350 mm
DN250	EN 1092-1	PN16	405 mm	437 mm	450 mm
DN300	EN 1092-1	PN16	460 mm	533 mm	500 mm
DN350	EN 1092-1	PN16	520 mm	563 mm	550 mm
DN400	EN 1092-1	PN16	580 mm	593 mm	600 mm
DN25	EN 1092-1	PN25	115 mm	181 mm	200 mm
DN32	EN 1092-1	PN25	140 mm	187 mm	200 mm
DN40	EN 1092-1	PN25	150 mm	197 mm	200 mm
DN50	EN 1092-1	PN25	165 mm	211 mm	200 mm
DN65	EN 1092-1	PN25	185 mm	231 mm	200 mm
DN80	EN 1092-1	PN25	200 mm	241 mm	200 mm
DN100	EN 1092-1	PN25	235 mm	267 mm	250 mm
DN125	EN 1092-1	PN25	270 mm	267 mm	250 mm
DN150	EN 1092-1	PN25	300 mm	321 mm	300 mm
DN200	EN 1092-1	PN25	360 mm	379 mm	350 mm
DN250	EN 1092-1	PN25	425 mm	437 mm	450 mm
DN25	EN 1092-1	PN40	115 mm	181 mm	200 mm
DN32	EN 1092-1	PN40	140 mm	187 mm	200 mm
DN40	EN 1092-1	PN40	150 mm	197 mm	200 mm
DN50	EN 1092-1	PN40	165 mm	211 mm	200 mm
DN65	EN 1092-1	PN40	185 mm	231 mm	200 mm
DN80	EN 1092-1	PN40	200 mm	241 mm	200 mm
DN100	EN 1092-1	PN40	235 mm	267 mm	250 mm
DN125	EN 1092-1	PN40	270 mm	267 mm	250 mm
DN150	EN 1092-1	PN40	300 mm	321 mm	300 mm
DN200	EN 1092-1	PN40	375 mm	379 mm	350 mm
DN250	EN 1092-1	PN40	450 mm	437 mm	450 mm

# PF75S (remote, one electrical connection)

Electromagnetic flow meter for industrial applications

PF75S-5#####1##3#####A#00#0

### Dimensional drawings (mm)

Nominal diameter	Process connection	Nominal pressure	D	H	L
DN3	ASME B 16.5 Class 150	PN16	88.9 mm	141.5 mm	200.0 mm
DN6	ASME B 16.5 Class 150	PN16	88.9 mm	141.5 mm	200.0 mm
DN10	ASME B 16.5 Class 150	PN16	88.9 mm	141.5 mm	200.0 mm
DN15	ASME B 16.5 Class 150	PN16	88.9 mm	141.5 mm	200.0 mm
DN20	ASME B 16.5 Class 150	PN16	98.4 mm	146.2 mm	200.0 mm
DN25	ASME B 16.5 Class 150	PN16	108.0 mm	195.0 mm	200.0 mm
DN32	ASME B 16.5 Class 150	PN16	117.3 mm	201.0 mm	200.0 mm
DN40	ASME B 16.5 Class 150	PN16	127.0 mm	211.0 mm	200.0 mm
DN50	ASME B 16.5 Class 150	PN16	152.4 mm	225.0 mm	200.0 mm
DN65	ASME B 16.5 Class 150	PN16	177.8 mm	245.0 mm	200.0 mm
DN80	ASME B 16.5 Class 150	PN16	190.5 mm	255.0 mm	200.0 mm
DN100	ASME B 16.5 Class 150	PN16	228.6 mm	281.0 mm	250.0 mm
DN125	ASME B 16.5 Class 150	PN16	254.0 mm	281.0 mm	250.0 mm
DN150	ASME B 16.5 Class 150	PN16	279.4 mm	335.0 mm	300.0 mm
DN200	ASME B 16.5 Class 150	PN16	342.9 mm	393.0 mm	350.0 mm
DN250	ASME B 16.5 Class 150	PN16	406.4 mm	451.0 mm	450.0 mm
DN300	ASME B 16.5 Class 150	PN16	482.6 mm	489.0 mm	500.0 mm
DN350	ASME B 16.5 Class 150	PN16	508.0 mm	502.0 mm	550.0 mm
DN400	ASME B 16.5 Class 150	PN16	584.5 mm	540.0 mm	600.0 mm

Attention: Nominal diameters DN3, DN6 and DN10 have process connections of size DN15

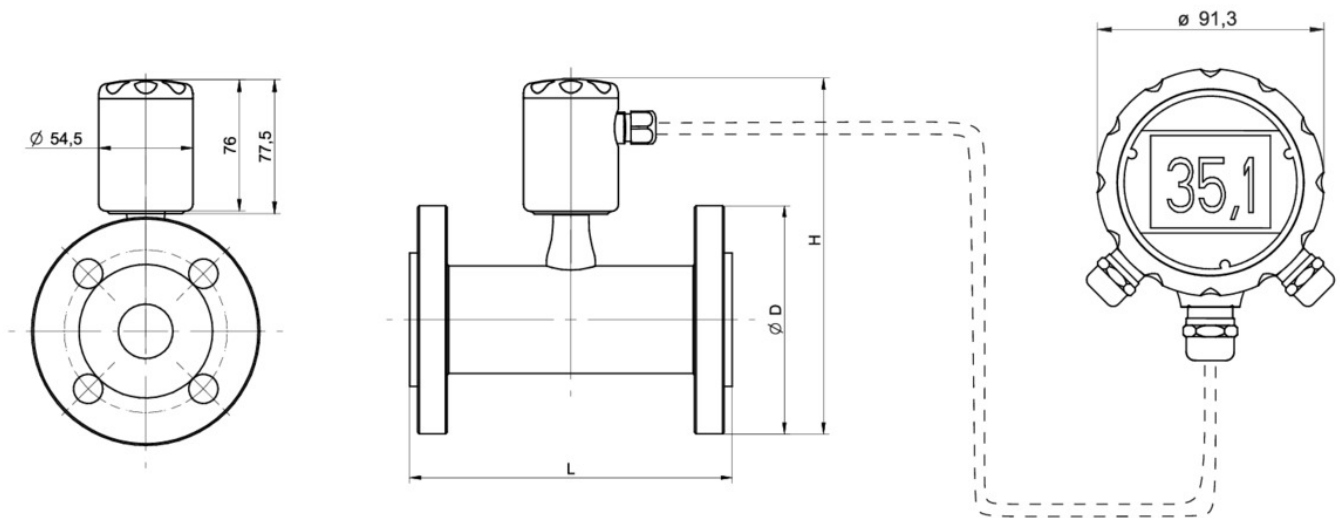

Nominal diameter	Process connection	Nominal pressure	D	H	L
DN3	1/2" DIN 228-1 male thread	PN16	76.0 mm	197 mm	128.0 mm
DN6	1/2" DIN 228-1 male thread	PN16	76.0 mm	197 mm	128.0 mm
DN10	3/4" DIN 228-1 male thread	PN16	76.0 mm	197 mm	128.0 mm
DN15	1" DIN 228-1 male thread	PN16	76.0 mm	197 mm	128.0 mm
DN20	1 1/4" DIN 228-1 male thread	PN16	76.0 mm	197 mm	128.0 mm

## PF75S (remote, one electrical connection)

Electromagnetic flow meter for industrial applications

PF75S-5#####1##3#####A#00#0

### Dimensional drawings (mm)

Nominal diameter	Process connection	Nominal pressure	D	H	L
DN3	1/2" NPT male thread	PN16	76 mm	197 mm	128 mm
DN6	1/2" NPT male thread	PN16	76 mm	197 mm	128 mm
DN10	3/4" NPT male thread	PN16	76 mm	197 mm	128 mm
DN15	1" NPT male thread	PN16	76 mm	197 mm	128 mm
DN20	1 1/4" NPT male thread	PN16	76 mm	197 mm	128 mm

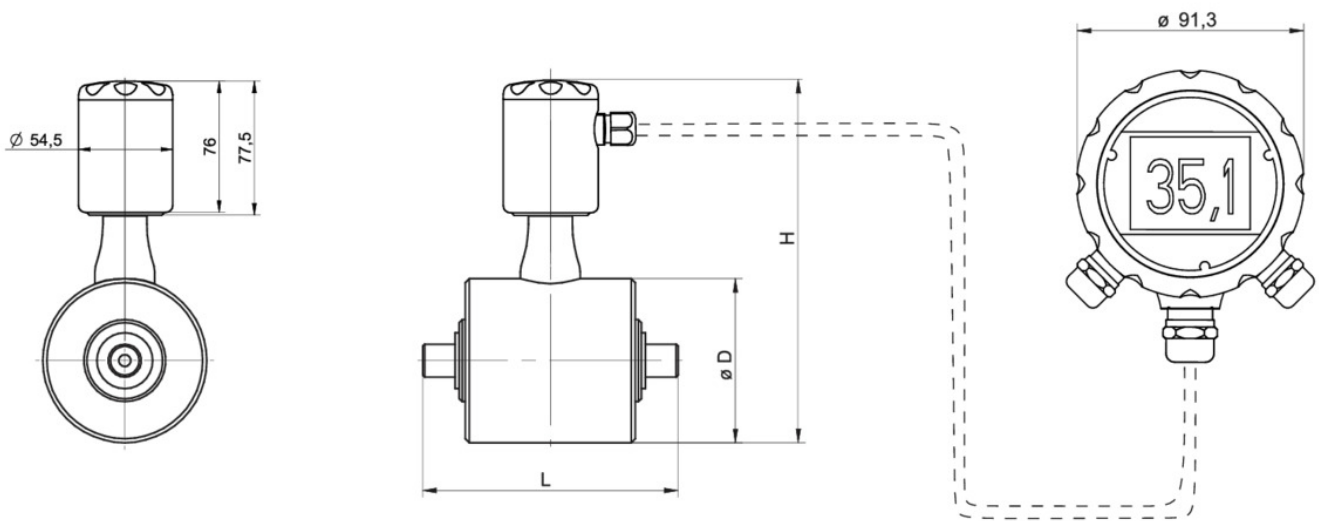

# PF75S (remote, one electrical connection)

Electromagnetic flow meter for industrial applications

PF75S-5#####1##3#####A#00#0

## Electrical connection

### M12-A, 5-pin

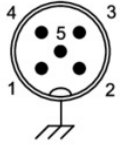

Left side connection



### Left side connection (front view): M12-A, 5-pin

Function			Pin assignment
V <sub>DC</sub> +	Power supply +	18 ... 30 V DC	1
V <sub>DC</sub> -	Power supply -	18 ... 30 V DC	3
mA+	Analog output	4 ... 20 mA	2
IO-Link/SW	IO-Link/SW		4
Out 1	Digital output 1	Selectable	5

### Terminal assignment transmitter

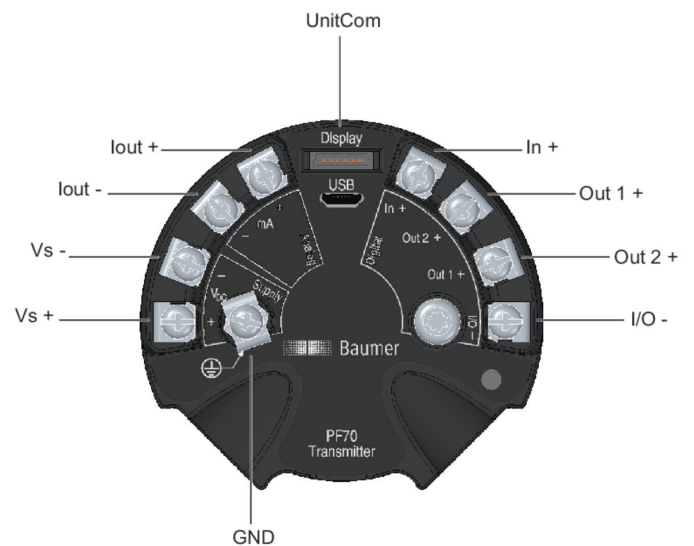

# PF75S (remote, one electrical connection)

Electromagnetic flow meter for industrial applications

PF75S-5#####1##3#####A#00#0

## Electrical connection

### Terminal assignment DFON display

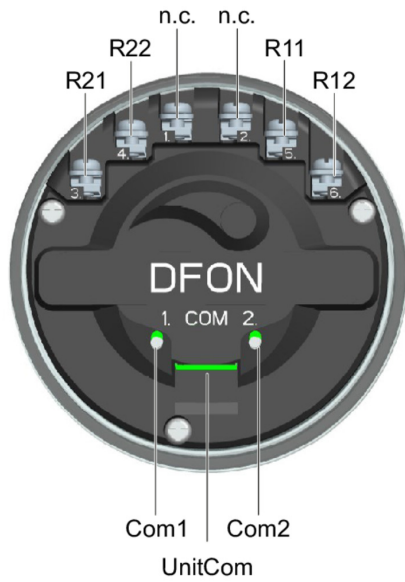

# PF75S (remote, one electrical connection)

Electromagnetic flow meter for industrial applications

PF75S-5#####1##3#####A#00#0

## Ordering information

Ordering key - Configuration possibilities see website

	PF75S	-	5	#	#	#	#	#	1	#	#	3	#	#	#	#	#	#	#	#	A	#	0	0	#	0
<b>Product</b>	PF75S																									
<b>Housing</b>																										
Stainless steel 1.4301 / AISI304			5																							
Bottom connection																										
<b>Max. measurement error</b>																										
±1.0 % o.r																										
±0.5 % o.r																										
±0.2 % o.r																										
<b>Display</b>																										
Without display																										
With display, with activated relays																										
<b>Output signal analog</b>																										
Without																										
4 ... 20 mA																										
<b>Output signal digital</b>																										
1 x Active pulse / frequency output (programmable)																										
2 x Active pulse / frequency output (programmable)																										
<b>Interface</b>																										
Without																										
HART®																										
<b>Electrical connection</b>																										
1 x M12-A, 5-pin																										
<b>Material of el. connection</b>																										
Plastic																										
Stainless steel, AISI 304 (1.4301)																										
<b>Converter version</b>																										
2 m																										
5 m																										
10 m																										
20 m																										
<b>Protection class</b>																										
IP65, IP67																										
<b>Process temperature (conti.)</b>																										
0 ... 60 °C																										
0 ... 70 °C																										
-5 ... 80 °C																										
-20 ... 100 °C																										
-20 ... 150 °C <sup>(1)</sup>																										
<b>Max. process pressure</b>																										
PN16																										
PN25																										
PN40																										



# PF75S (remote, one electrical connection)

Electromagnetic flow meter for industrial applications

PF75S-5#####1##3#####A#00#0

## Ordering information

Ordering key - Configuration possibilities see website

PF75S - 5 # # # # # 1 # # 3 # # # # # # # # # # A # 0 0 # 0

### Nominal diameter

DN3	A
DN6	B
DN10	C
DN15	D
DN20	E
DN25	F
DN32	G
DN40	H
DN50	I
DN65	J
DN80	K
DN100	L
DN125	M
DN150	N
DN200	O
DN250	P
DN300	Q
DN350	R
DN400	S

### Process connection

DIN 228-1 male thread	1
NPT male thread	2
EN 1092-1	A
ASME B 16.5 Class 150	B

### Sensor body and process connec

Painted steel	1
AISI 316L	2
AISI 304	3

### Liner material

PTFE	1
PP	3
Ebonite	4
Rilsan	5
Abral	6

### Electrodes material

AISI 316L	1
Hastelloy C	2
Titanium	4
Tantalum	5

### Number of electrodes

Two electrodes	2
Three electrodes	3
Four electrodes	4

### Surface finish

Ra ≤ 0,8 µm	A
-------------	---

# PF75S (remote, one electrical connection)

Electromagnetic flow meter for industrial applications

PF75S-5#####1##3#####A#00#0

## Ordering information

Ordering key - Configuration possibilities see website

	PF75S	-	5	#	#	#	#	#	1	#	#	3	#	#	#	#	#	#	#	A	#	0	0	#	0		
<b>Sealing-/ O-ring material (int)</b>																											
FKM																										1	
FFKM																											3
EPDM																											4
Sealing by lining																											7
<b>Special approvals</b>																											
Standard																											0
<b>Measuring Instr. Directive</b>																											
Without																											0
<b>Calibration certificate</b>																											
2 point calibration certificate (standard)																											0
3 point calibration certificate																											1
5 point calibration certificate																											2
10 point calibration certificate																											3
<b>Configuration / Parametrizatio</b>																											
Factory settings																											0

(1) With PTFE lining only for water, other media -20...100°C or on request