



Description of functions and interfaces

OE40
Edge sensors

EN-US

Table of contents

1 About this document	5
1.1 Purpose and scope of application	5
1.2 Applicable documents	5
1.3 Labels in this manual	5
1.4 Warnings in this manual	6
2 General functionality	7
3 Interfaces	9
3.1 IO-Link	9
4 Process data	11
5 Operating functions	12
5.1 Detection Mode (measuring mode)	12
5.2 Parameterization of edge position (transparent)	18
5.3 Filter	20
5.4 Zero position	23
5.5 Measuring range	24
5.6 MDC configuration	25
5.6.1 MDC descriptor	25
5.7 Switching points	25
5.7.1 Polarity	27
5.7.2 Hysteresis	28
5.7.3 Teaching	30
5.8 Analog output	31
5.9 Function of the output	32
5.10 Factory settings	33
6 Diagnostic functions	35
6.1 Measurement rate	35
6.2 Reply delay	35
6.3 Exposure reserve	36
6.4 Signal quality (alert of contamination)	37
6.5 Device status	38
6.6 Operating hours	38
6.7 Device temperature	38
6.8 Identification	39
7 Annex	40
7.1 IO-Link	40
7.1.1 PDI	40
7.1.2 Identification	41
7.1.3 Parameter	42

7.1.3.1	Device settings	42
7.1.3.2	MDC settings	42
7.1.3.3	SSC settings.....	43
7.1.3.4	Teach.....	44
7.1.3.5	Measurement range	44
7.1.3.6	Operation mode.....	45
7.1.3.7	Analog output	46
7.1.3.8	SIO settings	46
7.1.4	Diagnosis	46
7.1.4.1	Measurement value	46
7.1.4.2	Quality parameter	47
7.1.4.3	Device Status	47
7.1.4.4	Operating time	47
7.1.4.5	Operating temperature	47

List of illustrations

III. 1	IO-Link architecture.....	9
III. 2	<i>Edge position (transparent)</i> settings on the example of BSS.....	19
III. 3	<i>Moving Median</i> filter.....	21
III. 4	Moving Average filter.....	21
III. 5	Zero position.....	23
III. 6	Sensor in switching mode Point mode.....	25
III. 7	Sensor in switching mode Window mode.....	26
III. 8	Polarity – Active High.....	27
III. 9	Polarity – Active Low.....	27
III. 10	Positive hysteresis.....	28
III. 11	Behavior of the switching output in point mode (positive hysteresis).....	28
III. 12	Behavior of the switching output in window mode (positive hysteresis).....	29
III. 13	Analog output - Inverted.....	31
III. 14	Reply delay.....	35
III. 15	Representation of exposure reserve (with BSS as an example).....	36

1 About this document

1.1 Purpose and scope of application

This document enables safe and efficient sensor parameterization using various interfaces. The manual describes the available functions to support installation and software use via the interfaces.

The illustrations are examples only. Deviations are at the discretion of Baumer at all times. This manual is a supplement to the existing product documentation.

1.2 Applicable documents



- Available for download at www.baumer.com:
 - Functional and interface description
 - IODD
 - Data sheet
 - EU Declaration of Conformity
- Attached to product:
 - Quickstart
 - General information sheet (11042373)

1.3 Labels in this manual

Identifier	Usage	Example
<i>Dialog element</i>	Indicates dialog elements.	Click the OK button.
<i>Unique name</i>	Indicates the names of products, files, etc.	<i>Internet Explorer</i> is not supported in any version.
Code	Indicates entries.	Enter the following IP address: 192.168.0.250

1.4 Warnings in this manual

Warnings draw attention to potential personal injury or material damage. The warnings in this manual indicate different hazard levels:

Symbol	Warning term	Explanation
	DANGER	Indicates an imminent potential danger with high risk of death or serious personal injury if not being avoided.
	WARNING	Indicates potential danger with medium risk of death or (serious) personal injury if not being avoided.
	CAUTION	Indicates a danger with low risk, which could lead to light or medium injury if not avoided.
	NOTE	Indicates a warning of material damage.
	INFO	Indicates practical information and tips that enable optimal use of the devices.

2 General functionality

The sensor transmits a parallel light band in the size of its front screen. By a reflector, this band of light is returned on the same path back to the sensor where it hits a light-sensitive receiver. Any object present between sensor and reflector interrupts the band of light, shading the receiver. The transition between light and shade is called edge and evaluated by the sensor.

The emitted light is in the infrared range and therefore unperceivable for the human eye.

The sensor measures the position of one or more edges within the measuring field in a parallel axis towards the reflector. Edge detection can use different measuring modes:

- Edge position
- Edge position (transparent)
- Edge position (bi-direktional)
- Width
- Gap
- Gap center
- Object center

Measurement field

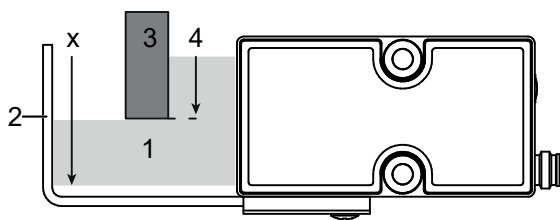

Pos.	Designation	Description
1	Measurement field	Parallel infrared light band, forms the measuring field of the sensor. The measurement object or the edge position must be in this area so that the sensor can take measurements.
2	Reflector	Reflects the transmitted light back into the exit window and thus to the receiver.
3	Measured object	Opaque or transparent object.
4	Edge position	Measured edge position in x-direction, i.e. parallel to the sensor front. Measurement result: Edge position in x-direction
x	Measuring direction	The sensor's measuring direction runs parallel to sensor front and reflector.



INFO

The distance to the object is limited. For the maximum distance please see the sensor data sheet.

The measured edge position can be provided at the following sensor-integrated channels:

- Digital IO-Link interface
- Analog output

Sensor parameterization is via IO-Link interface.

3 Interfaces

This section describes the available interfaces for operator to sensor communication.

3.1 IO-Link

IO-Link enables manufacturer-independent digital, bidirectional point-to-point communication. For this purpose, actuators or sensors are connected to an IO-Link master by standardized 3-wire connecting cables.

The IO-Link interface serves for parameterization of the sensor functions. In addition, measurement data and the function-generated sensor and status information are digitally transmitted in the form of process data to the machine controller (PLC). Secondary data informing on the machine condition allow for continuous process monitoring and process optimization.

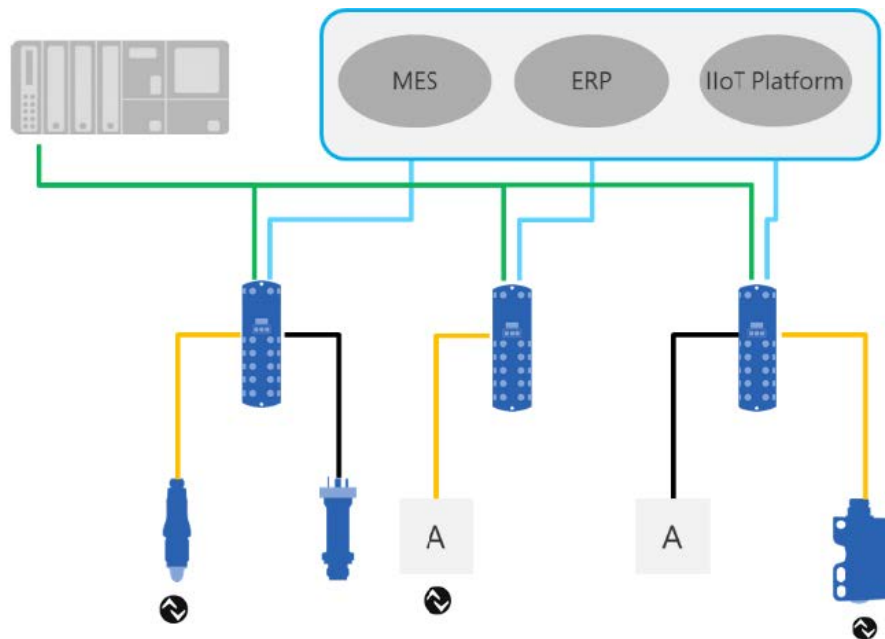

III. 1: IO-Link architecture

The IO-Link master clustering several sensors connects the controller via the respective fieldbus system, which is the so-called operational technology communication (OT communication). In addition, another Ethernet-based connection to the IO-Link master (e.g., via OPC UA or MQTT) enables direct communication between sensor and IT systems (IT communication).

There are two types of communication between IO-Link master and device.

- **Cyclic communication:**
transmission in real time - This data and information (process data) is used for process control in automation systems.
- **Acyclic communication:**
Time-uncritical communication for secondary data transmission or sensor parameterization.

To address both sensor functions and secondary data correctly, IO-Link interface description utilizes the so-called IODD (IO Device Description). IODD is available for download on the sensor website (download section). Digital sensor communication, secondary data and the option of direct sensor communication with the IT world makes IO-Link a cornerstone in Smart Factory.

**INFO**

For evaluation, parameterization and use of IO-Link sensors, Baumer provides both IO-Link USB-C master and Baumer Sensor Suite. The IO-Link USB-C Master enables IO-Link devices to communicate with the computer without external power supply. Baumer Sensor Suite is a computer-based tool to understand and use IO-Link devices and to visualize sensor functions of different sensor brands. This allows for engineering both at the workplace and straight at the machine. Further information at [baumer.com/bss](https://www.baumer.com/bss).

4 Process data

If the sensor is in IO-Link communication mode, the process data is exchanged cyclically between the IO-Link master and the sensor (sensor<>IO-Link master). The IO-Link master needn't explicitly request the process data.

This sensor follows the *DMSS (Digital Measuring Switching Sensor) profile SSP4.3.1*. Following process data is available:

Process Data In (PDI)

For more detailed information on the following please refer to chapter [Annex \[▶ 40\]](#).

Bit Offset	Sub index	Function	Description
0	24	SSC1.1 (Switching Signal Channel)	Status of the switching output. <ul style="list-style-type: none"> Bit 0 = 0: Switching output for SSC 1.1 is inactive. Bit 0 = 1: Switching output for SSC 1.1 is active.
1	23	SSC1.2 (Switching Signal Channel)	<ul style="list-style-type: none"> Bit 1 = 0: Switching output for SSC 1.2 is inactive. Bit 1 = 1: Switching output for SSC 1.2 is active.
2	22	Quality	Signal quality status. <ul style="list-style-type: none"> Bit 2 = 0: Signal quality is good. Bit 2 = 1: Signal quality is insufficient. The sensor should be checked for contamination.
3	21	Alarm	Alarm output status. <ul style="list-style-type: none"> Bit 3 = 0: Alarm is inactive. Sensor is functioning as required. Bit 3 = 1: Alarm is active. The sensor must be checked. No measured value can be recorded.
16	1	Process value	Sensor-supplied measured value. Error values according to Smart Sensor Profile: <ul style="list-style-type: none"> Measurement value: -0.024..0.024 Out of range (-): -2.65E+38 Out of range (+): 2.65E+38 No measurement data: 3.3E+38

Tab. 1: Process Data In



INFO

Measured values are output in meters [m], as defined in the IO-Link Smart Sensor profile.

5 Operating functions

5.1 Detection Mode (measuring mode)

Sensor operation can use four different measuring modes:

- Edge position (edge position)
- Edge position (transparent) (edge position for transparent objects)
- Edge position (bi-direktional) (edge position from both directions)
- Width (width)
- Gap (gap)
- Center gap (center of gap)
- Center object (center of object)

Edge position

Mode *Edge position* is used to measure the edge position of the object.

Several edges in the sensor's measuring range will have detected and output the position of first edge from right (point of view reflector bracket respectively connector).



INFO

In measuring modes *Edge position*, *Edge position (transparent)*, *Edge position (bi-direktional)*, *Center gap* and *Center object* the zero point is in the middle of the measuring range (default). For example, according to the measuring range, edge positions may be measured from -12 to 12 mm.

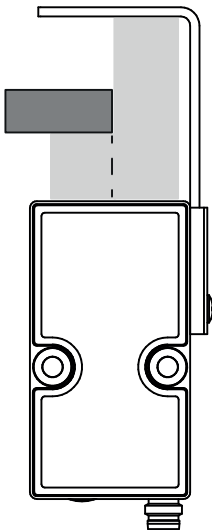

Behavior in the event of error - no valid measuring operation feasible:

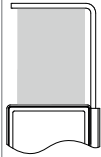
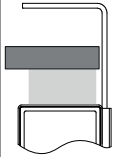
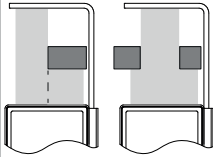
	No object	Measuring range coverage	Invalid combinations
Example			
Measured value	Out of Range (+)	Out of Range (-)	No measurement data
Analog output behavior	20 mA	4 mA	Depends on the setting in parameter <i>Invalid Value Handling</i> of the analog output. Default: 4 mA
Alarm output	Enabled	Enabled	Enabled

Edge position (transparent)

Mode *Edge position (transparent)* is particularly for detecting transparent objects (e.g. glass). This measuring mode corresponds to mode *Edge position* and hence measures the edge positions of an object within the measurement field.

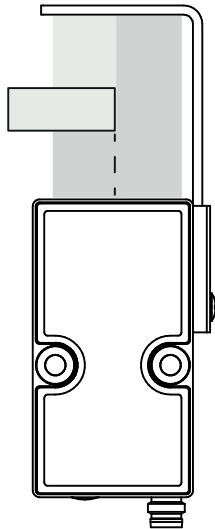

With transparent objects, shading is down to a minimum. It is therefore important that even slightest differences in the intensity of the signal received will be detected.

For doing so, this mode provides two more functions:

- Teaching of reflector foil (Teach)
- Defined threshold for edge detection



INFO

Behavior in the event of error is the same as in measuring mode "Edge position".

For more details please see chapter [Parameterization of edge position \(transparent\)](#) [▶ 18].

Edge position (bi-direktional)

Mode *Edge position (bi-direktional)*, is used to measure the edge position of the object from both directions. Unlike in mode *Edge position*, the object direction does not matter.



INFO

In measuring modes *Edge position*, *Edge position (transparent)*, *Edge position (bi-direktional)*, *Center gap* and *Center object* the zero point is in the middle of the measuring range (default). For example, according to the measuring range, edge positions may be measured from -12 to 12 mm.

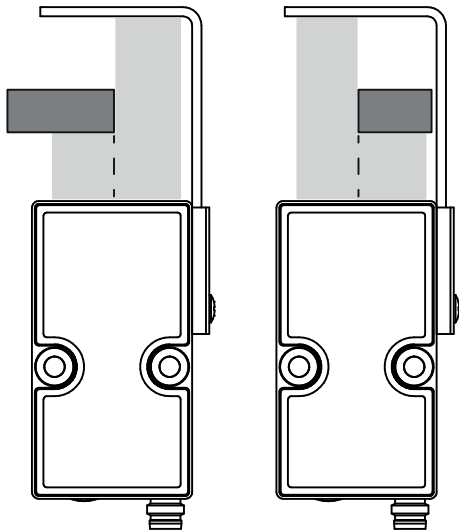

Behavior in the event of error - no valid measuring operation feasible:

	No object	Measuring range coverage	Special combination
Example			
Measured value	Out of Range (+)	Out of Range (-)	First edge = measuring position
Analog output behavior	20 mA	4 mA	The analog output is set depending on the measured position
Alarm output	Enabled	Enabled	Enabled

Width

Mode *Width* is for measuring the object width. This requires at least two edges to be detected within the measuring range.

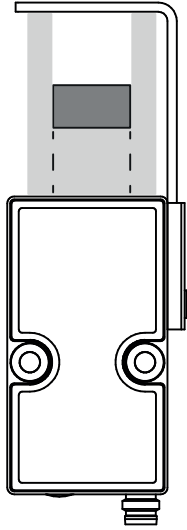

INFO

In mode "Width" and "Gap" the measuring range may be from 0 to 24 mm, analog to the sensor's measuring range.

Behavior in the event of error - no valid measuring operation feasible:

	No object	Measuring range coverage	Invalid combinations
Example			
Measured value	Out of Range (+)	Out of Range (-)	No measurement data
Analog output behavior	20 mA	4 mA	Depends on the setting in parameter <i>Invalid Value Handling</i> of the analog output. Default: 4 mA
Alarm output	Enabled	Enabled	Enabled

Gap

Measuring mode *Gap* is for gap detection between two objects. This requires at least two edges to be detected within the measuring range.

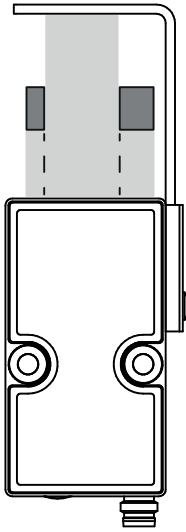

Behavior in the event of error - no valid measuring operation feasible:

	No object	Measuring range coverage	Invalid combinations
Example			
Measured value	Out of Range (+)	Out of Range (-)	No measurement data
Analog output behavior	20 mA	4 mA	Depends on the setting in parameter <i>Invalid Value Handling</i> of the analog output. Default: 4 mA
Alarm output	Enabled	Enabled	Enabled

Center gap

Measurement mode *Center gap* is for measuring the center of a gap between two objects. This requires at least two edges to be detected within the measuring range.

If there are several gaps in the measuring field, the center of the first gap is measured in ascending x-direction.

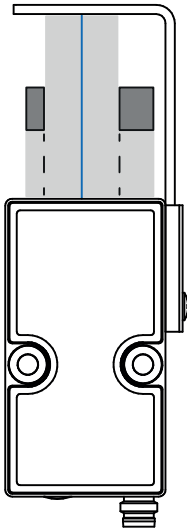
**INFO**

Behavior in the event of error is the same as in measuring mode "Width".

Center object

Measurement mode *Center object* is for measuring the center point of an object. This requires at least two edges to be detected within the measuring range.

If there are several objects within the measuring field, the center measured refers to the outermost edges.

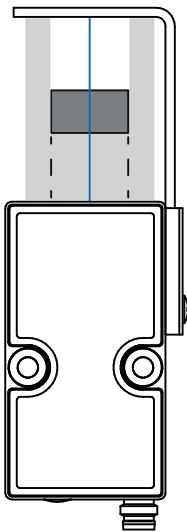
**INFO**

In mode "Width" and "Gap" the measuring range may be from 0 to 24 mm, analog to the sensor's measuring range.

**INFO**

Behavior in the event of error is the same as in measuring mode "Width".

For more detailed information on the following please refer to chapter [Annex \[▶ 40\]](#).

IO-Link access: Detection mode

Name	Index	Subindex	Description
Detection mode	77	2	Selection of the detection mode. <ul style="list-style-type: none"> ▪ 0: Edge position ▪ 2: Width ▪ 3: Gap ▪ 4: Edge position (transparent) ▪ 5: Center object ▪ 6: Center gap ▪ 10: Edge position (bi-directional)

5.2 Parameterization of edge position (transparent)

Mode *Edge position (transparent)* is for detection of transparent objects.

Transparent objects do not produce any shading at the receiver. Only the edge will cause a weak drop in the received signal. For this reason, edge detection parameters must be set to high sensitivity. For doing so, two functions are available:

- Teaching of reflector foil (Teach)
- Defined threshold for edge detection

Teaching of reflector foil (Teach)

If transparent objects are to be detected, even the smallest signal fluctuations in the received signal can have a disruptive effect. Teaching the signal received at the reflector is therefore recommended. This allows for measuring operations independent from any reflector tolerances and ensures maximum reliability.

How to proceed:

Instruction:

- a) Take the object to be measured out of the sensor's measuring range.
- b) Teach the reflector signal.

Setting the threshold for edge detection

Transparent edges produce only very light drops in the signal received, reason why the threshold for edge detection should be correspondingly adjusted.

How to proceed:

- a) Position the transparent object in the sensor's measuring range.
- b) Evaluate the line signal via IO-Link.
- c) Adjust the threshold (parameter *Detection threshold*).

**INFO**

Recommended to set the threshold (*Detection threshold*) as low as possible to prevent that any signal drops caused by a contaminated sensor front might recognized as an edge.

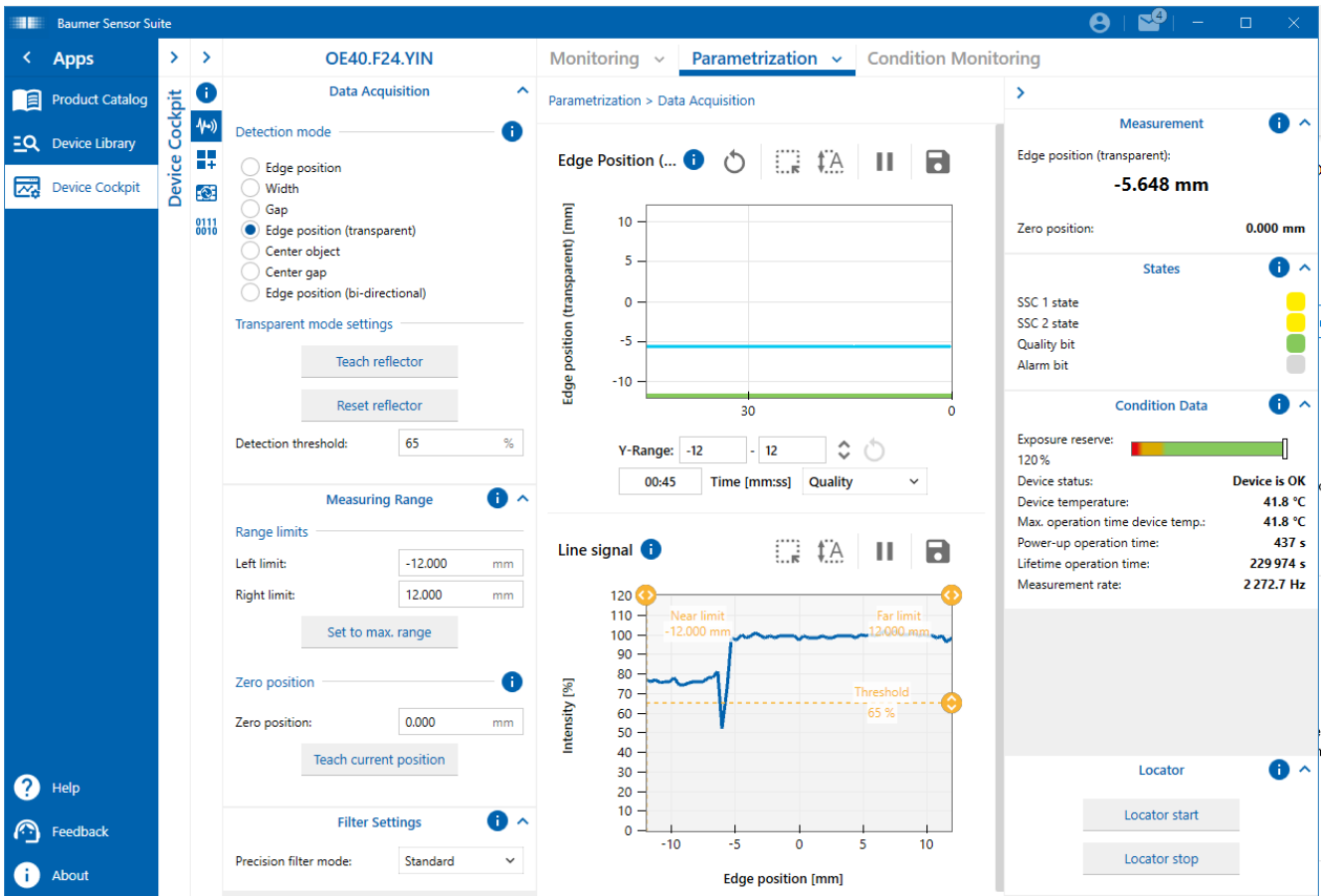

III. 2: Edge position (transparent) settings on the example of BSS

There are two ways for adjusting the threshold in BSS (view *Device Cockpit*):

- Using the horizontal cursor in diagram *Line signal*
- Via the percentage in the parameter list (Detection threshold)

For more detailed information on the following please refer to chapter [Annex \[▶ 40\]](#).

IO-Link access: Teach reflector

Name	Index	Subindex	Description
Baumer Command – Teach reflector	1000	–	Set value 129 to teach reflector.
Baumer Command – Reset reflector	1000	–	Set value 130 to reset value to default.

IO-Link access: Detection threshold

Name	Index	Subindex	Description
Detection threshold	77	7	Adjustable threshold value from which an edge is detected. This parameter is only used for <i>Detection mode = edge position (transparent)</i> .

5.3 Filter

Using the filter function, noise can be reduced while repeatability precision is improved.

The number of measured values per string of numbers (filter length) can be adjusted as follows via the parameter settings:

- Option 1: Select the required filter length from predefined filter lengths.
 - Standard
 - High
 - Very High
 - Highest
- Option 2: Enter the required filter length as a numerical value.
 - Custom

General

The response and drop-off times are increased and moving objects detected with a delay as a result. The precision filter calculates the results in the form of floating values. The oldest measured value will be removed as soon as a new one is added. Therefore the measuring frequency is not affected by the precision filter.

In general, the more measured values per filter, the better the repeatability and the higher the reproducibility of the results.

Moving Median filter

This filter allows the suppression of individual measurement errors by calculating the median of a specified number of measured values in a string of numbers. The median value is the measured value located right “in the center” if the measured values are sorted by size.

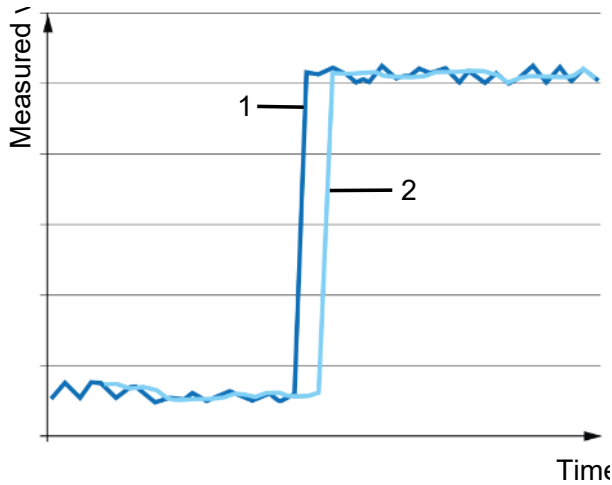

III. 3: Moving Median filter

- | | | | |
|---|----------|---|---|
| 1 | Raw data | 2 | Data after filtering with Moving Median |
|---|----------|---|---|

Moving Average filter

This filter smooths the signal course by calculating the average of a specified number of measured values in a string of numbers. The calculated average will indicate any change in the measured value in ascending order.

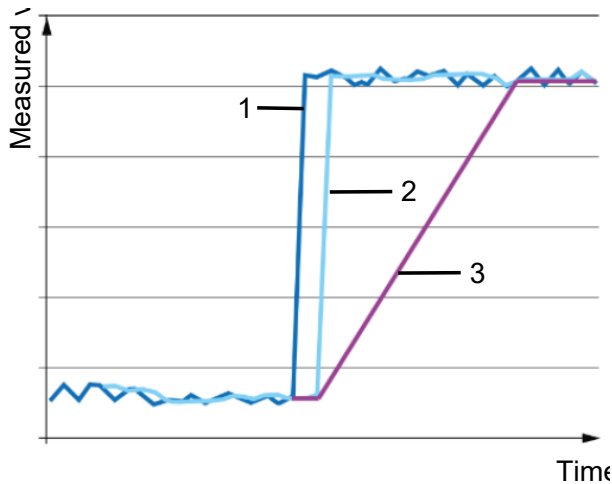

III. 4: Moving Average filter

- | | | | |
|---|--|---|---|
| 1 | Raw data | 2 | Data after filtering with Moving Median |
| 3 | Data after filtering with Moving Average and Moving Median | | |

The higher the number of measured values per filter, the longer the response time of the sensor. This means that a change in distance only becomes fully visible for the output after a delay.

Option 1: Select the required filter length from predefined filter lengths

The following selection options are available:

Value	Number of measured values	
	Moving Median	Moving Average
Standard	1	1
High	9	1
Very High	9	16
Highest	9	128

Option 2: Enter the filter length as a numerical value

If the predefined filter lengths are not suitable, an individual filter length can be entered for the *Moving Average* and *Moving Median* filters. You can specify the length of the *Moving Average* and *Moving Median* filters after selecting the *Custom* filter.

- *Moving Median* filter: 1 - 21 values
- *Moving Average* filter: 1 - 256 values

IO-Link access: Filter

Name	Index	Subindex	Description
Precision filter	77	1	Selection between Standard, High, Very high, Highest and Custom filter.
Custom moving median length	77	8	Length of the moving median filter if Precision filter 4 (Custom) is selected.
Custom moving average length	77	9	Length of the moving average filter if Precision filter 4 (Custom) is selected.

5.4 Zero position

The measured value relates to the defined zero position. By default, the sensor's zero position is congruent to the center of the measuring range. It can be set to any value within the sensor's measuring range.

The measured value, the analog output and the switching point positions are calculated by reference to the zero position.

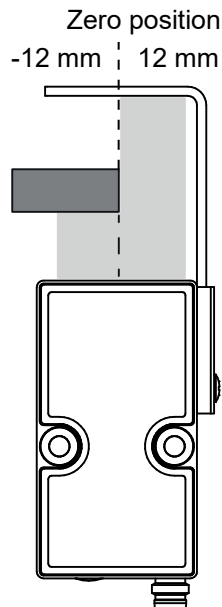

III. 5: Zero position



INFO

The zero function is only available in edge mode and edge mode (transparent).

There are two options for setting the zero position:

- by input as a numerical value
- by teach-in

Teaching the zero position:

- a) Place the object in the required zero position.
- b) Teach-i the zero position.

Example 1:

- Physical edge position within the measuring range: -5 mm
- Set zero position: 0 mm (default)
- Output measured value: -5 mm

Example 2:

- Physical edge position within the measuring range: -5 mm
- Set zero position: -3 mm
- Output measured value: -2 mm

IO-Link parameter: Zero position

Name	Index	Subindex	Description
Zero Position.Zero Position	105	1	In 'Edge position' detection mode, the measurement value is shifted by the zero position.
Baumer Commands – Zero Position Teach	1000	–	Value 208 = Zero position teach

5.5 Measuring range

The function is used to limit the active measuring range to a part of the sensor's maximum measuring range.

The intention is to hide edges that should not go into the evaluation of the measured value.

The alarm output is active when there is no object present in the defined measurement range or when the signal quality is insufficient.

In *BSS*, the measuring range limits can be set directly in diagram *Line Signal*(view *Device Cockpit*):



For more detailed information on the following please refer to chapter [Annex \[40 \]](#).

IO-Link access: SIO settings

Name	Index	Subindex	Description
Left limit	66	1	Left limit of the measurement range.
Right limit	66	2	Right limit of the measurement range.

5.6 MDC configuration

5.6.1 MDC descriptor

This function reads out the measuring range limits of the set MDC source. The sensor detecting a value out of range will report error *Out of range*(32760).

For more detailed information on the following please refer to chapter [Annex ▸ 40](#).

IO-Link access: MDC source

Name	Index	Subindex	Description
Lower Limit	16512	1	Lower value of displayable process value range.
Upper Limit	16512	2	Upper value of displayable process value range.
Unit Code	16512	3	Unit code of the selected process value.
Scale	16512	4	Scale exponent x (10^x) of the selected process value.

5.7 Switching points

Function *switching points* defines the measured values (switching points) the switching output will be activated at.

The function can be configured via the following parameters:

- Select switching mode (point mode or window mode).
- Define the position of the switching points (SP1 and SP2):
 - Point mode: SP1
 - Window mode: SP1 and SP2



INFO

Using the *Baumer Sensor Suite* for configuration, you may have to change the view in add-on [↔](#) to access the required settings.

To change the view, click on next to **Parametrization**. Next select the view from the drop-down list.

Point mode



III. 6: Sensor in switching mode Point mode

- Purpose/application (example):
 - Align the object until it is in the required edge position.

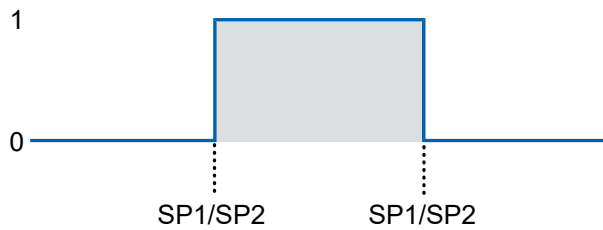
Window mode

III. 7: Sensor in switching mode Window mode

- Purpose/application (example):
 - Quality control: Checking the object width within a tolerance window.

For more detailed information on the following please refer to chapter [Annex \[▶ 40\]](#).

IO-Link access: switching points

Name	Index	Subindex	Description
Switching signal channel 1.1			
SSC1.1 Mode	61	2	Selects the SSC switch mode. <ul style="list-style-type: none"> ▪ 0: Deactivated ▪ 1: Single point ▪ 2: Window
SSC1.1 Setpoint 1	60	1	Defines the process value at which SSC1.1 is set to active.
SSC1.1 Setpoint 2	60	2	Defines the process value at which SSC1.1 is set to inactive.
Switching signal channel 1.2			
SSC1.2 Mode	63	2	Selects the SSC switch mode. <ul style="list-style-type: none"> ▪ 0: Deactivated ▪ 1: Single point ▪ 2: Window
SSC1.2 Setpoint 1	62	1	Defines the process value at which SSC1.2 is set to active.
SSC1.2 Setpoint 2	62	2	Defines the process value at which SSC1.2 is set to inactive.

5.7.1 Polarity

Using this function you define the switching output behavior in relation to the output level.

In parameterization you can choose between *Active High* and *Active Low*.

Active High

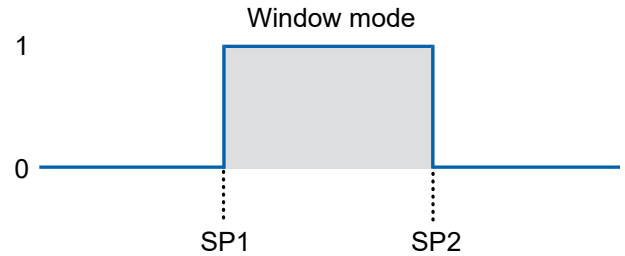
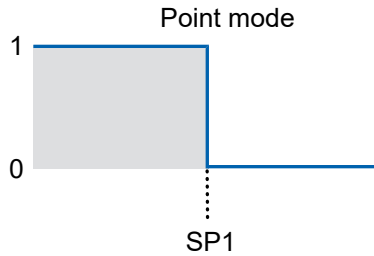

/// 8: Polarity – Active High

- Point mode: switching output is enabled when dropping below the defined measured value SP1.
- Window mode: The switching output is activated as soon as the measured value is within the window of SP1 and SP2.

Active Low

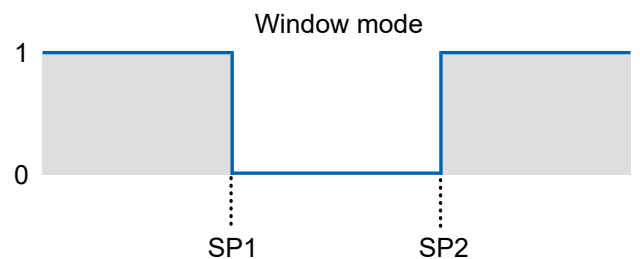
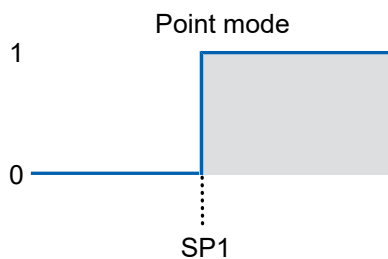

/// 9: Polarity – Active Low

- Point mode: switching output is enabled when exceeding the defined measured value SP1.
- Window mode: The switching output is activated as soon as the measured value is outside the window of SP1 and SP2.

For more detailed information on the following please refer to chapter [Annex \[▶ 40\]](#).

IO-Link access: Polarity

Name	Index	Subindex	Description
SSC1.1 Logic	61	1	Selects the SSC logic: <ul style="list-style-type: none"> ■ 0: High active ■ 1: Low active
SSC1.2 Logic	63	1	Selects the SSC logic: <ul style="list-style-type: none"> ■ 0: High active ■ 1: Low active

5.7.2 Hysteresis

The function prevents unwanted switching operations at the switching output. The parameterized value of the hysteresis is the difference in distance between the points at which the switching output is activated and deactivated. Baumer recommends always setting the hysteresis not equal to 0.

Positive hysteresis

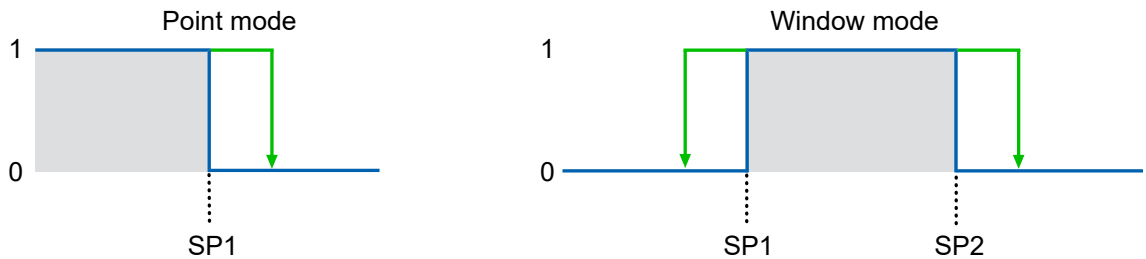

III. 10: Positive hysteresis

- Switching output in point mode: A positive hysteresis value corresponds to a right-justified hysteresis.
- Switching output in window mode: A positive hysteresis value corresponds to a hysteresis aligned outside of the window.



INFO

This hysteresis behavior corresponds to IO-Link Smart Sensor Profile DMSS with extension "Object detection".

Point mode (switching output behavior)

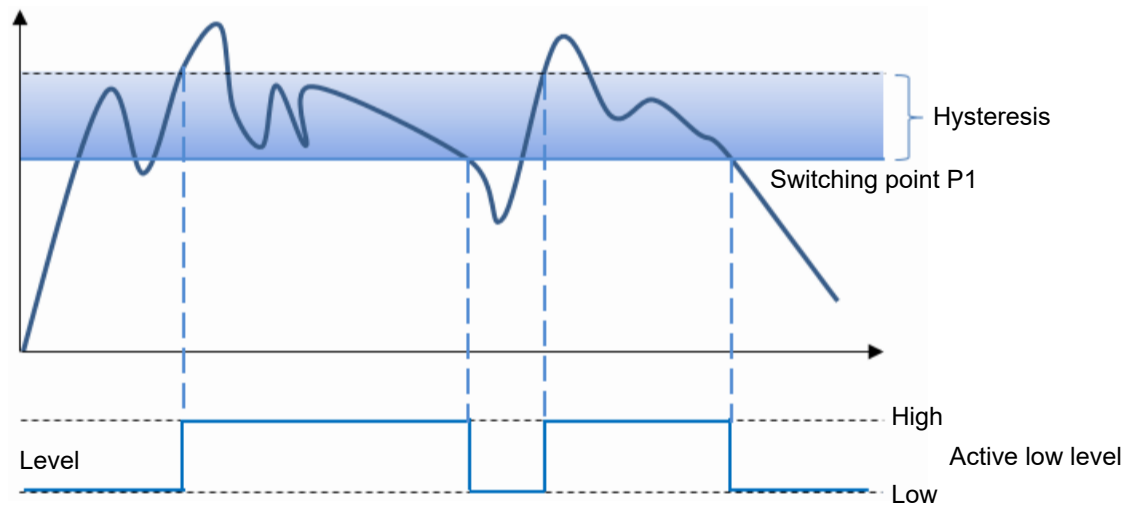

III. 11: Behavior of the switching output in point mode (positive hysteresis)

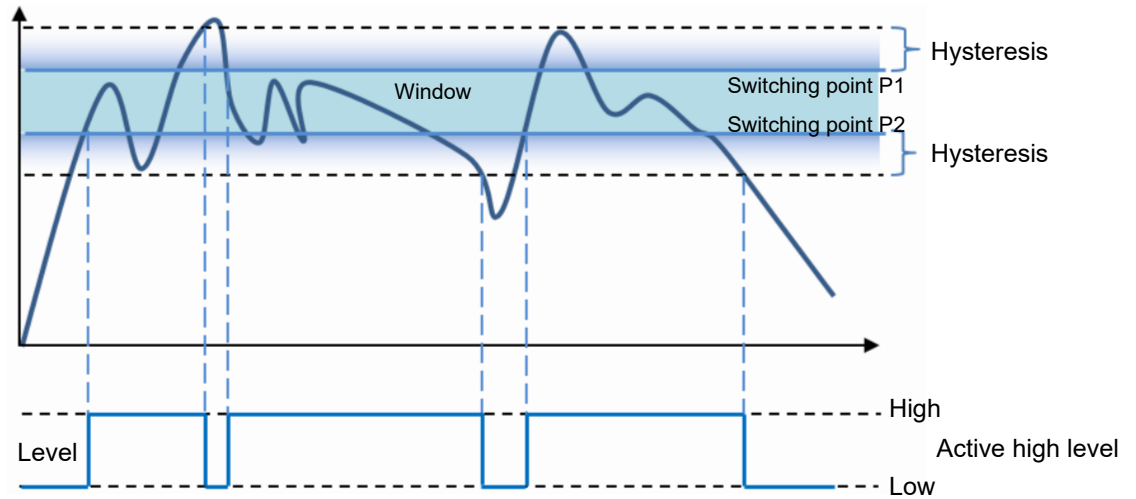
Window mode (switching output behavior)

III. 12: Behavior of the switching output in window mode (positive hysteresis)

For more detailed information on the following please refer to chapter [Annex \[▶ 40\]](#).

IO-Link access: hysteresis

Name	Index	Subindex	Description
SSC1.1 Hyst width	61	3	The hysteresis width of SSC1.1.
SSC1.2 Hyst width	63	3	The hysteresis width of SSC1.2.

5.7.3 Teaching

Teach commands can be used for setting the switching points 1 and (SP1 and SP2). This is an easy way to compensate individual deviations such as mechanical backlash and mounting tolerances.

The switching behavior of the individual switching signal channels depends on the individual configuration (e.g. switching mode, channel logic).

For more detailed information on the following please refer to chapter [Annex \[▶ 40\]](#).

IO-Link access: Teaching

Teaching commands can be applied to individual switching signal channels. Prior to the teaching operation, select the SSC to be addressed.

Name	Index	Subindex	Description
Teach select	58	1	Selects the switching signal channel for which a teach procedure will be applied. <ul style="list-style-type: none"> ▪ 1 = SSC1.1 ▪ 2 = SSC1.2
Teach result.State	59	1	<ul style="list-style-type: none"> ▪ 0 - Idle ▪ 1 - SP1 Success ▪ 2 - SP2 Success ▪ 3 - SP12 Success ▪ 4 - Waiting for command ▪ 5 - Busy ▪ 7 - Error
System Command – Teach SP1	2	–	Set SP1 at the current position of the object which is within the scanning range.
System Command – Teach SP2	2	–	Set SP2 at the current position of the object which is within the scanning range.

5.8 Analog output

The analog output is permanently scaled throughout the entire measuring range.

Parameter *Value after dropout* defines the sensor behavior when detecting invalid measured values. Invalid measured values come up when the number of edges in the measuring range is invalid (e.g. width mode requires detection of two edges minimum). You have the following options:

- Minimum value - Analog output holds the min. output point.
- Maximum value - Analog output holds the max. output point.
- Last valid - Analog output holds the last valid measured value.

Parameter *Output characteristic* can invert the analog output.

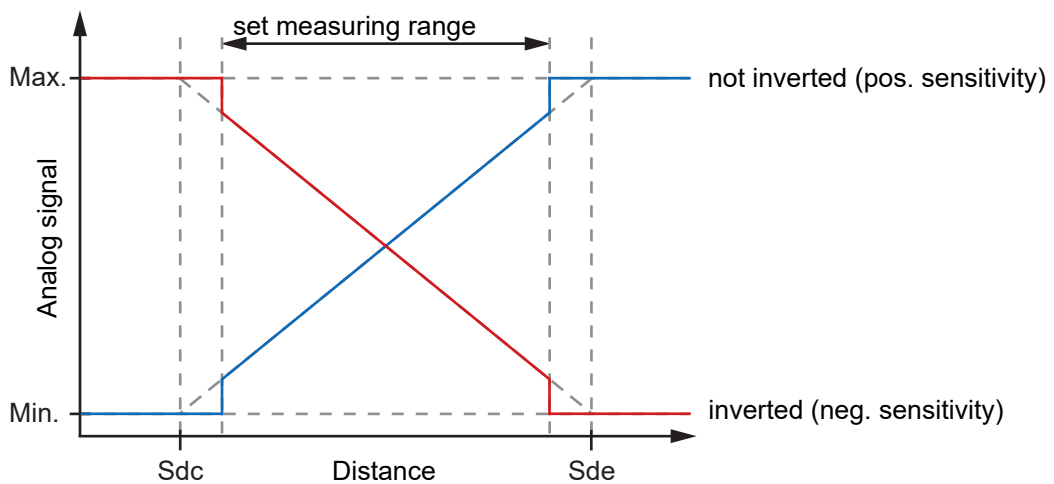

Ill. 13: Analog output - Inverted



INFO

Using the *Baumer Sensor Suite* for configuration, you may have to change the view in add-on [↔](#) to access the required settings.

To change the view, click on **▼** next to **Parametrization**. Next select the view from the drop-down list.

For more detailed information on the following please refer to chapter [Annex ▶ 40](#).

IO-Link access: analog output

Name	Index	Subindex	Description
Value after dropout	116	4	Behavior of the analog output in case of an invalid measurement value. <ul style="list-style-type: none"> ▪ 1: Minimum value ▪ 2: Maximum value ▪ 4: Last valid
Output characteristic	202	10	Defines if the analog output is inverted or not. <ul style="list-style-type: none"> ▪ 0: Not inverted ▪ 1: Inverted

5.9 Function of the output

The IO-Link communication principle can also be used as a switching output. In the factory settings, the function of the output is equivalent to the alarm output. This means that the output is activated as soon as no measured value can be recorded.

Via IO-Link you select the functionality of the switching output. You have four options:

- SSC1.1
- SSC1.2
- Alarm
- Quality (alert of contamination)

For more detailed information on the following please refer to chapter [Annex \[▶ 40\]](#).

IO-Link access: SIO settings

Name	Index	Subindex	Description
SIO1 Function selection	78	2	Defines the function of the switching output (SIO1). <ul style="list-style-type: none"> ▪ 100: SSC1.1 ▪ 200: SSC1.2 ▪ 101: Alarm bit ▪ 102: Quality bit

5.10 Factory settings

This function restores default in the entire sensor values and parameterization. Default will be restored in the entire user settings. You have the following options:

Designation	Description
Application Reset	Restores default in the parameterization of the technology-specific application. Identification parameters will be retained. If enabled, an upload to the data memory of the master is executed.
Restore Factory Settings	Restores default in all device parameters. Note: A download of the data memory can be executed at next device power on to overwrite the default settings.
Back-to-box	Restores default in all device parameters and communication is blocked until next device power on. Note: Disconnect device straight at the master port.

Overview on default settings

Parameter		Factory settings
Operation Mode	Detection mode	Edge position
	Precision Filter	Standard
Measurement Range	Zero Position	0 mm
	Left Limit	-12 mm *
	Right Limit	12 mm *
SSC1.1 Configuration	SP1	0 mm
	SP2	-2 mm
	Polarity	Normal
	Mode	Single Point
	Hysteresis	0.2 mm
SSC1.1 Configuration	SP1	0 mm
	SP2	-2 mm
	Polarity	Normal
	Mode	Single Point
	Hysteresis	0.2 mm
Analog Output Settings	Value after dropout	Min. value
	Output Characteristics	Not inverted
Input/Output Settings	OUT1 Mode	Alarm
	Output & LED function	

* = value according to measuring range (see data sheet)

For more detailed information on the following please refer to chapter [Annex \[▶ 40\]](#).

IO-Link access: Reset options

Name	Index	Subindex	Description
System Command	2	–	<ul style="list-style-type: none">▪ 129 = Application Reset▪ 130 = Restore Factory Settings▪ 131 = Back-to-box

6 Diagnostic functions

6.1 Measurement rate

This function outputs the measuring rate in [Hz]. The measurement rate is equivalent to the number of measurements per second.

Example: A measuring rate of 500 Hz means a measuring operation is executed every 0.002 s ($1/500 \text{ Hz} = 0.002 \text{ s}$). The measurement rate is useful for the following questions, among others:

- How quickly will any change be detected (e.g. position, width)?
- How many measuring operations can be performed towards a static object?



INFO

The max. speed in dynamic applications is limited by the measurement rate, and the distance change at the output is influenced by the selected filter value settings. Therefore, consider the measurement rate in connection with the settings of the filter.

For more detailed information on the following please refer to chapter [Annex \[▶ 40\]](#).

IO-Link access: Measuring rate

Name	Index	Subindex	Description
Measurement value	88	2	Returns the measurement rate in Hz.

6.2 Reply delay

The reply delay is equivalent to the time elapsed between the triggering of the measurement (internal signal) and the change in the measured value at the output.

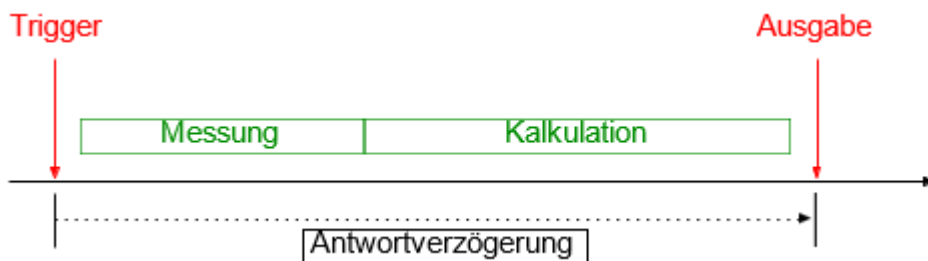

Ill. 14: Reply delay

For more detailed information on the following please refer to chapter [Annex \[▶ 40\]](#).

IO-Link access: response delay

Name	Index	Subindex	Description
Response delay	88	9	Returns the response delay in us.

6.3 Exposure reserve

Exposure reserve (Exposure reserve) represents the amount of light reflected by the reflector (as a relative factor without specifying a measuring unit). The exposure reserve can be used for sensor alignment towards the reflector. 110-120% exposure reserve describes the optimum condition.

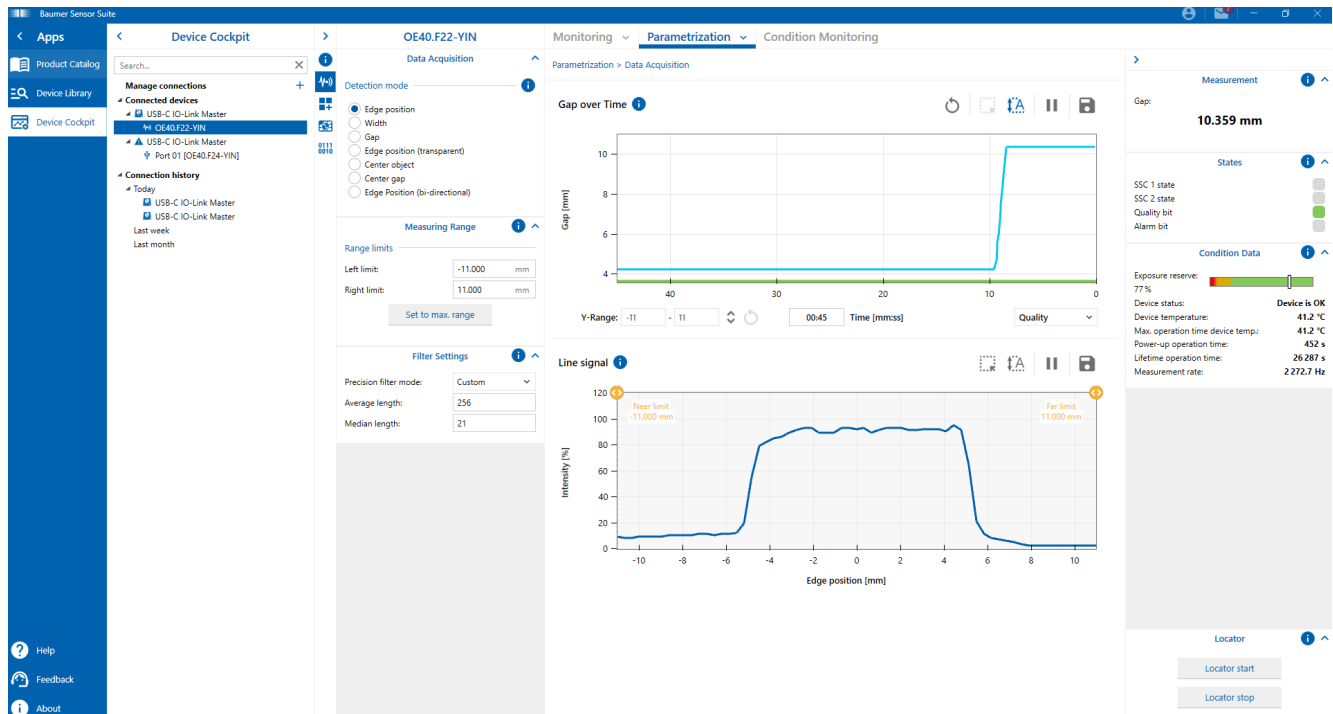

III. 15: Representation of exposure reserve (with BSS as an example)

A drop in the exposure reserve may give evidence that sensor alignment is not optimal or the sensor is contaminated. However, as long as the exposure reserve is in the green range, no further actions are required.

For more detailed information on the following please refer to chapter [Annex \[▶ 40\]](#).

IO-Link access: Exposure reserve

Name	Index	Subindex	Description
Exposure reserve	64	1	Represents the exposure reserve in %

6.4 Signal quality (alert of contamination)

The signal quality serves as an indication of the reliability of the measurement.

The sensor's signal quality may be impaired by a contaminated front glass or reflector. Both point-shaped and surface contamination like dust will be detected and come up as local signal drops. Also scratches on the front glass or at the reflector may impair signal quality.

For more detailed information on the following please refer to chapter [Annex ▶ 40J](#).

IO-Link access: Signal quality

Name	Index	Subindex	Description
Quality	64	2	Indicates if the sensor is not, slightly or strong contaminated. <ul style="list-style-type: none"> ■ 0 = 0: No contamination ■ 1 = 1: Slight contamination ■ 2 = 2: Strong contamination*

* Potential root causes: Sensor front or reflector are soiled and need to be cleaned. Sensor or reflector damage (e.g. by scratches). Check the sensor.



INFO

The alert of contamination is not available in transparent edge mode. This mode requires detection of even the slightest drops in the line signals which must not produce an alert of contamination.

6.5 Device status

This function is for retrieving information on the device status.

For more detailed information on the following please refer to chapter [Annex \[▶ 40\]](#).

IO-Link access: Device status

Name	Index	Subindex	Description
Device Status	36	–	Indicator for the current device condition and diagnosis state. <ul style="list-style-type: none"> ■ 0 – Device is OK ■ 1 – Maintenance required ■ 2 – Out of specification ■ 3 – Functional check ■ 4 – Failure
Detailed Device Status	37	1	–

6.6 Operating hours

The operating time of the sensor is permanently recorded. This function reads out the total of the sensor's operating hours.

For more detailed information on the following please refer to chapter [Annex \[▶ 40\]](#).

IO-Link access: Operating hours

Name	Index	Subindex	Description
Operation time. Power-on time	211	1	Powerup Operation Time
Operation time. Lifetime	211	3	Lifetime Operation Time

6.7 Device temperature

This function reads the sensor's temperature information.

For more detailed information on the following please refer to chapter [Annex \[▶ 40\]](#).

IO-Link access: Device temperature

Name	Index	Subindex	Description
Current device temperature	208	1	Current device temperature in [°C].
Maximum device temperature	208	3	Maximum device temperature since power-on in [°C].

6.8 Identification

These functions read or write sensor identification information.

For more detailed information on the following please refer to chapter [Annex ▸ 40](#).

IO-Link access: Identification

Name	Index	Subindex	Description
Vendor Name	16	–	The vendor name that is assigned to a Vendor ID. Default value: Baumer Electric AG
Vendor Text	17	–	Additional information about the vendor. Default value: www.baumer.com
Product Name	18	–	Complete product name.
Product ID	19	–	Vendor-specific product or type identification (e.g. item number or model number).
Product Text	20	–	Additional product information for the device.
Application-specific Tag	24	–	Possibility to mark a device with user- or application-specific information.
Function Tag	25	–	User specified function tag.
Location Tag	26	–	User specified location tag.
Serial Number	21	–	Unique, vendor-specific identifier of the individual device.
Firmware Revision	23	–	Unique, vendor-specific identifier of the firmware revision of the individual device.
Hardware Revision	22	–	Unique, vendor-specific identifier of the hardware revision of the individual device.

7 Annex

7.1 IO-Link

7.1.1 PDI

subindex	bit offset	data type	allowed values	default value	acc. restr.	mod. other var.	excl. from DS	name	description
1	16	Float32	-2.65E+38 = Out of range (-), 2.65E+38 = Out of range (+), 3.3E+38 = No measurement data, -0.024..0.024					Process value	
21	3	Boolean						Alarm	
22	2	Boolean						Quality	
23	1	Boolean						SSC1.2	
24	0	Boolean						SSC1.1	

Octet 0

bit offset	47	46	45	44	43	42	41	40
subindex	1							
element bit	31	30	29	28	27	26	25	24

Octet 1

bit offset	39	38	37	36	35	34	33	32
subindex	1							
element bit	23	22	21	20	19	18	17	16

Octet 2

bit offset	31	30	29	28	27	26	25	24
subindex	1							
element bit	15	14	13	12	11	10	9	8

Octet 3

bit offset	23	22	21	20	19	18	17	16
subindex	1							
element bit	7	6	5	4	3	2	1	0

Octet 4

bit offset	15	14	13	12	11	10	9	8
subindex	/////	/////	/////	/////	/////	/////	/////	/////

Octet 5

bit offset	7	6	5	4	3	2	1	0
subindex	/////	/////	/////	/////	21	22	23	24

7.1.2 Identification

Index	Subindex	Name	Data type	Access rights	Value range	Description
16	0	Vendor Name	String	R	ASCII	Vendor name that is assigned to a vendor ID, e. g. Baumer.
17	0	Vendor Text	String	R	ASCII	Additional information about the vendor, e. g. www.baumer.com
18	0	Product Name	String	R	ASCII	Complete product name, e. g. IFxx.DxxL.
19	0	Product ID	String	R	ASCII	Vendor-specific product or type identification, e. g. item number or model number.
20	0	Product Text	String	R	ASCII	Additional product information for the device.
21	0	Serial number	String	R	ASCII	Unique, vendor-specific identifier of the individual device.
22	0	Hardware revision	String	R	ASCII	Unique, vendor-specific identifier of the hardware revision of the individual device, e. g. 00.00.01
23	0	Firmware Revision	String	R	ASCII	Unique, vendor-specific identifier of the firmware revision of the individual device, e.g. 00.00.04
24	0	Application specific Tag	String	R/W	ASCII	Possibility to mark a device with user-or application-specific information.
25	0	Function Tag	String	R/W	ASCII	Possibility to mark a device with function-specific information.
26	0	Location Tag	String	R/W	ASCII	Possibility to mark a device with location-specific information.

7.1.3 Parameter

7.1.3.1 Device settings

Index	Subindex	Name	Data type	Access rights	Value range	Description
2	–	System Command.Ap- plication Reset	UInt8	W		The parameter of the technology-specific application are set to default values. Identification parameter remain unchanged. An upload to the data storage of the master will be executed, if activated in the port configuration of the master.
2	–	System Command.Re- store Factory Settings	UInt8	W		The parameter of the device are reset to factory settings. Note: A download of the data storage may be executed on the next power cycle and overwrite the factory default settings!
2	–	Back-to-box	UInt8	W		The parameter of the device are set to factory default values and communication will be inhibited until the next power cycle. Note: Directly detach the device from the master port!

7.1.3.2 MDC settings

Index	Subindex	Name	Data type	Access rights	Value range	Description
16512	1	Lower Limit	Float32	R		Lower value of displayable process value range.
16512	2	Upper Limit	Float32	R		Upper value of displayable process value range.
16512	3	Unit Code	UInt16	R		Unit code of the selected process value.
16512	4	Scale	UInt8	R		Scale exponent x (10^x) of the selected process value.

7.1.3.3 SSC settings

Index	Subindex	Name	Data type	Access rights	Value range	Description
Switching signal channel 1.1						
60	1	SSC1.1 Setpoint 1	Uint32	R/W	-0.022 ... 0.022	Defines the process value at which SSC1.1 is set to active.
60	2	SSC1.1 Setpoint 2	Uint32	R/W	-0.022 ... 0.022	Defines the process value at which SSC1.1 is set to inactive.
61	1	SSC1.1 Logic	Uint8	R/W		Selects the SSC logic: <ul style="list-style-type: none"> ▪ 0: High active ▪ 1: Low active
61	2	SSC1.1 Mode	Uint8	R/W		Selects the SSC switch mode. <ul style="list-style-type: none"> ▪ 0: Deactivated ▪ 1: Single point ▪ 2: Window
61	3	SSC1.1 Hyst width	Uint32	R/W	1E-05 .. 0.022	The hysteresis width of SSC1.1.
Switching signal channel 1.2						
62	1	SSC1.2 Setpoint 1	Uint32	R/W	-0.022 ... 0.022	Defines the process value at which SSC1.2 is set to active.
62	2	SSC1.2 Setpoint 2	Uint32	R/W	-0.022 ... 0.022	Defines the process value at which SSC1.2 is set to inactive.
63	1	SSC1.2 Logic	Uint8	R/W		Selects the SSC logic: <ul style="list-style-type: none"> ▪ 0: High active ▪ 1: Low active
63	2	SSC1.2 Mode	Uint8	R/W		Selects the SSC switch mode. <ul style="list-style-type: none"> ▪ 0: Deactivated ▪ 1: Single point ▪ 2: Window
63	3	SSC1.2 Hyst width	Uint32	R/W	1E-05 .. 0.022	The hysteresis width of SSC1.2.

7.1.3.4 Teach

Index	Subindex	Name	Data type	Access rights	Value range	Description
58	1	Teach select	UInt32	R		<p>Selects the switching signal channel for which a teach procedure will be applied.</p> <ul style="list-style-type: none"> ■ 1 = SSC1.1 ■ 2 = SSC1.2
59	1	Teach result.State	UInt32	R		<ul style="list-style-type: none"> ■ 0 - Idle ■ 1 - SP1 Success ■ 2 - SP2 Success ■ 3 - SP12 Success ■ 4 - Waiting for command ■ 5 - Busy ■ 7 - Error

7.1.3.5 Measurement range

Index	Subindex	Name	Data type	Access rights	Value range	Description
Zero position						
105	1	Zero position	Float32	R/W	-0.011 ... 0.011	In 'Edge position' detection mode, the measurement value is shifted by the zero position.
1000	–	Zero position teach	UInt8	W		
Range						
66	1	Left limit	Float32	R/W	-0.011 ... 0.011	Left limit of the measurement range.
66	2	Right limit	Float32	R/W	-0.011 ... 0.011	Right limit of the measurement range.

7.1.3.6 Operation mode

Index	Subindex	Name	Data type	Access rights	Value range	Description
77	1	Precision filter	Uint8	R/W		Selection of the precision filter. <ul style="list-style-type: none"> ■ 0: Standard ■ 1: High ■ 2: Very high ■ 3: Highest ■ 4: Custom
77	2	Detection mode	Uint8	R/W		Selection of the detection mode. <ul style="list-style-type: none"> ■ 0: Edge position ■ 2: Width ■ 3: Gap ■ 4: Edge position (transparent) ■ 5: Center object ■ 6: Center gap ■ 10: Edge position (bi-directional)
77	7	Detection threshold	Uint16	R/W	0 ... 100	Adjustable threshold value from which an edge is detected.
77	8	Custom moving median length	Uint16	R/W	1 ... 21	Length of the moving median filter if Precision filter 4 (Custom) is selected.
77	9	Custom moving average length	Uint16	R/W	1 ... 256	Length of the moving average filter if Precision filter 4 (Custom) is selected.

7.1.3.7 Analog output

Index	Subindex	Name	Data type	Access rights	Value range	Description
116	4	Value after dropout	UInt8	R/W		Behavior of the analog output in case of an invalid measurement value. <ul style="list-style-type: none"> ■ 1 = 1: Minimum value ■ 2 = 2: Maximum value ■ 4 = 4: Last valid
202	10	Output characteristic	UInt8	R/W		Defines if the analog output is inverted or not. <ul style="list-style-type: none"> ■ 0 = 0: Not inverted ■ 1 = 1: Inverted

7.1.3.8 SIO settings

Index	Subindex	Name	Data type	Access rights	Value range	Description
78	2	SIO1 Function selection	UInt16	R/W		Defines the function of the switching output (SIO1). <ul style="list-style-type: none"> ■ 100 = 100: SSC1.1 ■ 101 = 101: Alarm bit ■ 102 = 102: Quality bit ■ 200 = 200: SSC1.2

7.1.4 Diagnosis

7.1.4.1 Measurement value

Index	Subindex	Name	Data type	Access rights	Value range	Description
88	2	Measurement value	Float32	R		Returns the measurement rate in Hz.
88	9	Response delay	UInt32	R		Returns the response delay in us.

7.1.4.2 Quality parameter

Index	Subindex	Name	Data type	Access rights	Value range	Description
64	1	Exposure reserve	UInt64	R	0 ... 120	Represents the exposure reserve in %
64	2	Quality	UInt32	R		Indicates if the sensor is not, slightly or strong contaminated. <ul style="list-style-type: none"> ■ 0 = 0: No contamination ■ 1 = 1: Slight contamination ■ 2 = 2: Strong contamination

7.1.4.3 Device Status

Index	Subindex	Name	Data type	Access rights	Value range	Description
64	1	Device Status	UInt32	R		Indicator for the current device condition and diagnosis state. <ul style="list-style-type: none"> ■ 0 = Device is OK ■ 1 = Maintenance required ■ 2 = Out of specification ■ 4 = Failure
64	2	Detailed Device Status	Array	R		List of all currently pending events in the device.

7.1.4.4 Operating time

Index	Subindex	Name	Data type	Access rights	Value range	Description
211	1	Operating time	UInt32	R		Time since power-on in seconds.
211	3	Lifetime	UInt32	R		Total lifetime in seconds.

7.1.4.5 Operating temperature

Index	Subindex	Name	Data type	Access rights	Value range	Description
208	1	Current device temperature	Float32	R		Current device temperature in [°C].
208	3	Maximum device temperature	Float32	R		Maximum device temperature since power-on in [°C].

