

**Overview**

- Extended functional reserve capacities for maximum reliability
- Object detection through smallest holes and gaps without blind area thanks to single-lens optics
- Parallel laser beam for uniform detection over the measuring range
- qTeach - tamper-proof, simple teach-in with ferromagnetic tool
- Quick mounting by means of M3 threaded bushes made of stainless steel



Picture similar



**Technical data**

**General data**

Type	Retro-reflective sensor
Version	Single lens optics
Light source	Pulsed red laser diode
Actual range Sb	0.8 m
Nominal range Sn	1.2 m
Smallest object recognizable typ.	3 mm at 500 mm
Polarization filter	Yes
Alignment / soiled lens indicator	Flashing output indicator
Output indicator	LED yellow
Power on indication	LED green
Sensitivity adjustment	qTeach
Laser class	1
Distance to focus	Parallel beam
Wave length	680 nm
Suppression of reciprocal influence	Yes
Alignment optical axis	< 1,5°

**Electrical data**

Response time / release time	< 0.1 ms
Jitter	< 0.03 ms

**Electrical data**

Voltage supply range +Vs	10 ... 30 VDC
Current consumption max. (no load)	20 mA (@ 10 VDC)
Current consumption typ.	10 mA (@ 24 VDC)
Voltage drop Vd	<2 VDC
Output function	Light / dark operate
Output circuit	PNP complementary
Output current	50 mA
Short circuit protection	Yes
Reverse polarity protection	Yes

**Mechanical data**

Width / diameter	8 mm
Height / length	25.1 mm
Depth	15.8 mm
Design	Rectangular
Mechanical mounting	Threaded sleeves M3 (stainless steel)
Housing material	Plastic (ASA, PMMA)
Front (optics)	PMMA
Connection types	Cable 4 pin, 2 m
Cable characteristics	PVC / PVC 4 x 0.08 mm <sup>2</sup>

**Ambient conditions**

Operating temperature	-20 ... +50 °C
Protection class	IP 67

**Technical drawings**

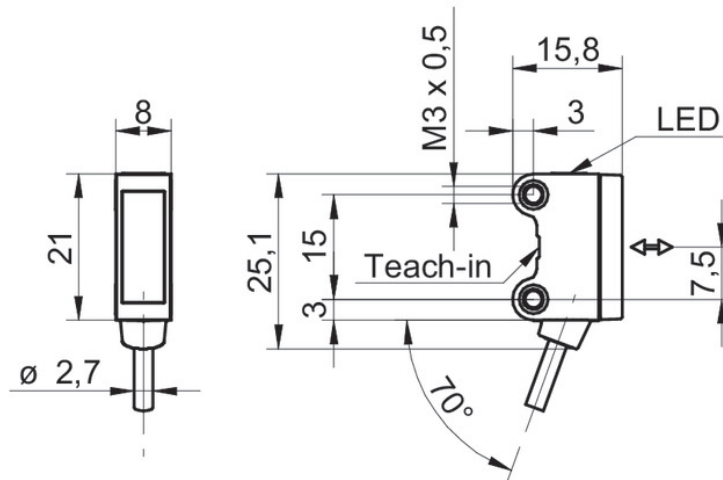

**Connection diagram**

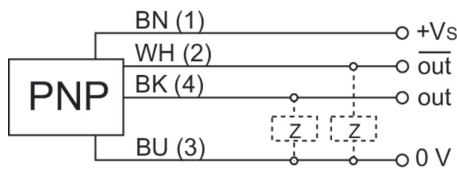

**Beam characteristic (typically)**

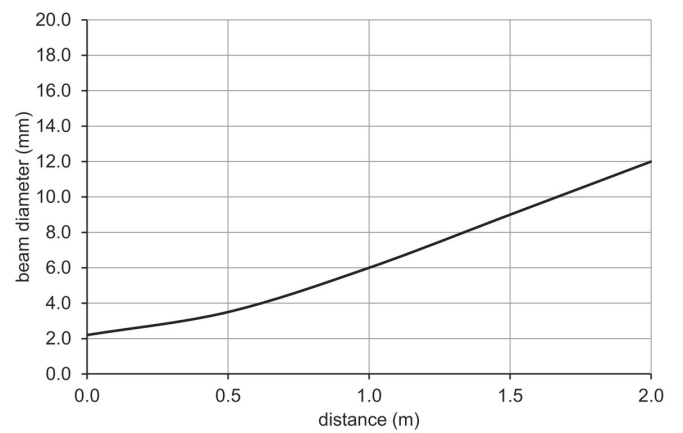

**Laser warning**

**CLASS 1 LASER  
PRODUCT**

IEC 60825-1/2014  
Complies with 21 CFR 1040.10 and 1040.11 except for conformance with IEC 60825-1 Ed. 3., as described in Laser Notice No. 56, dated May 8, 2019

**Excess gain curve**

