

## ITD69H02 - Rectangular signal

Through hollow shaft  $\varnothing 40$  to  $\varnothing 68$  mm

128...4096 pulses per revolution

### Overview

- Bearingless magnetic encoder
- Max. 4096 pulses per revolution
- Output circuits: HTL or TTL
- Fast, easy and space saving installation
- Maintenance-free
- High accuracy - error max.  $\pm 0.2^\circ$
- Rotation speed max. 6000 rpm
- High resistance to dirt and vibrations
- Magnetic rotor included in delivery



Picture similar

### Technical data

#### Technical data - electrical ratings

Voltage supply	5 VDC $\pm 5\%$ 8...26 VDC
Reverse polarity protection	Yes
Short-circuit proof	Yes
Consumption w/o load	$\leq 50$ mA
Pulses per revolution	128 ... 4096
Interpolation	1-fold (single) 2-fold 4-fold 8-fold 16-fold 32-fold
Output signals	A 90° B + inverted A 90° B, N + inverted
Output stages	TTL linedriver (short-circuit proof) HTL push-pull (short-circuit proof)
Output current	$\leq 30$ mA
Output frequency	$\leq 300$ kHz (TTL) $\leq 160$ kHz (HTL)

#### Technical data - electrical ratings

System accuracy	$\pm 0.2^\circ$
Interference immunity	EN 61000-6-2
Emitted interference	EN 61000-6-3

#### Technical data - mechanical design

Shaft type	$\varnothing 40$ ... $\varnothing 68$ mm (through hollow shaft)
Dimensions (sensor head)	12 x 16 x 49 mm
Protection EN 60529	IP 67 (relating to sealed electronics)
Operating speed	$\leq 6000$ rpm
Working distance	0.2 ... 0.5 mm (radial), optimal 0,3 mm
Axial offset	$\pm 0.5$ mm
Material	Housing: plastic Shaft: stainless steel
Operating temperature	$-40$ ... $+100$ °C (fixed cable)
Resistance	EN 60068-2-6 Vibration 10 g, 55-2000 Hz EN 60068-2-27 Shock 100 g, 11 ms
Weight approx.	390 g
Connection	Cable 1 m

### Optional

- Cable with connector
- Redundant sensing

# ITD69H02 - Rectangular signal

Through hollow shaft  $\varnothing 40$  to  $\varnothing 68$  mm

128...4096 pulses per revolution

## Terminal assignment

### With BI-signals, cable [4x2x0,08 mm<sup>2</sup>]

Core colour	Assignment
green	Track A
yellow	Track A inv.
grey	Track B
pink	Track B inv.
red	UB
blue	GND
transparent	Shield/Housing

### With NI-signals, cable [4x2x0,08 mm<sup>2</sup>]

Core colour	Assignment
green	Track A
yellow	Track A inv.
grey	Track B
pink	Track B inv.
brown	Track N
white	Track N inv.
red	UB
blue	GND
transparent	Shield/Housing

## Output signals

Clockwise rotation when looking at the mounting side.

### BI-Output signals

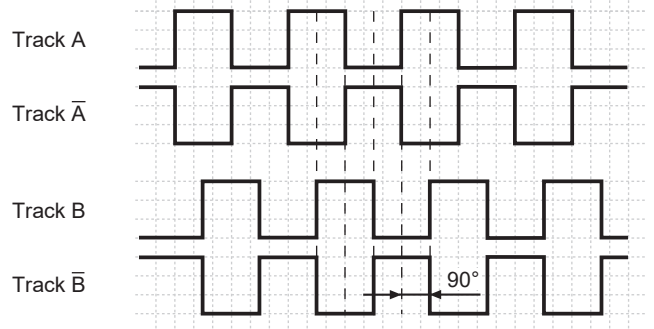

### NI-Output signals

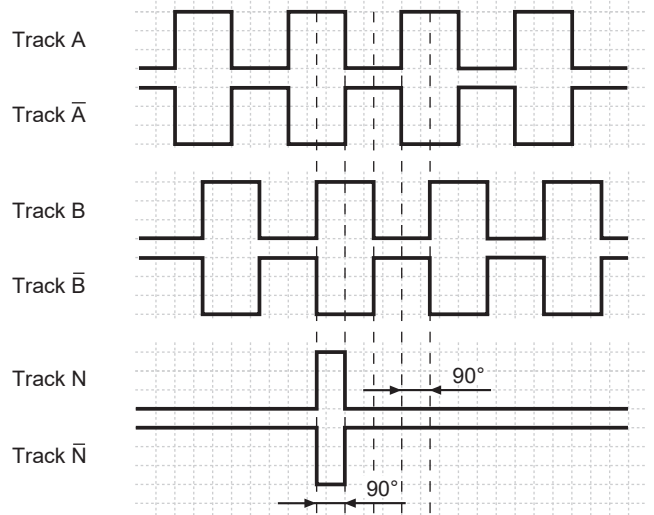

## Trigger level

Outputs	Linedriver
Output level High	$\geq 2,5$ V
Output level Low	$\leq 0,5$ V
Load	$\leq 30$ mA

  

Outputs	Push-pull short-circuit proof
Output level High	$\geq UB - 3$ V
Output level Low	$\leq 1,5$ V
Load	$\leq 30$ mA

# ITD69H02 - Rectangular signal

Through hollow shaft  $\varnothing 40$  to  $\varnothing 68$  mm  
128...4096 pulses per revolution

## Dimensions

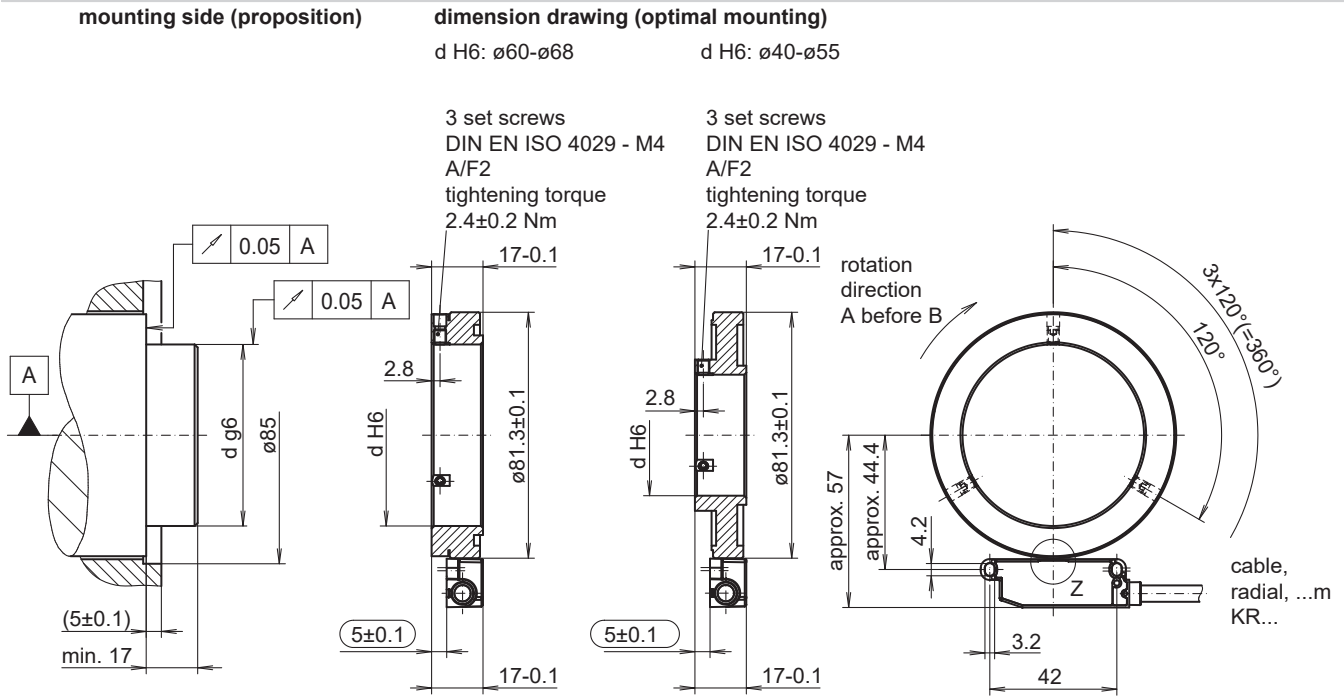

## Mounting tolerances, operating tolerances

Permitted change of position sensor to rotor during mounting and operation:

### Axial offset:

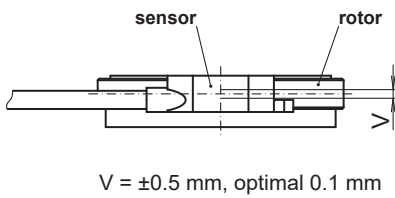

### Working distance:

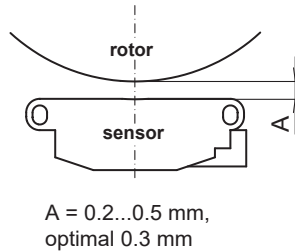

Use the distance band as a mounting tool for optimal gap (0.3 mm) between sensor and rotor.

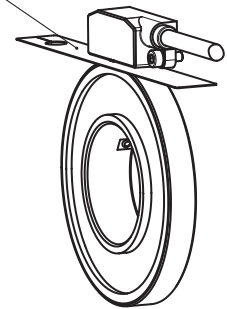

## Mounting position

Mounting position (1-1) sensor to rotor should not be altered!

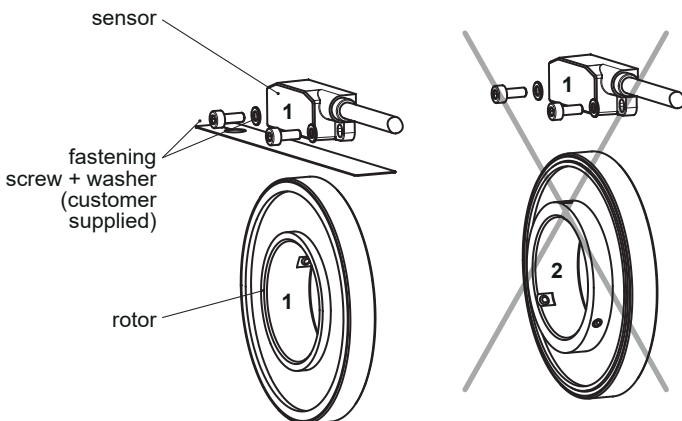

# ITD69H02 - Rectangular signal

 Through hollow shaft  $\varnothing 40$  to  $\varnothing 68$  mm

128...4096 pulses per revolution

**Ordering reference**

	ITD69H02	#####	#	####	KR1	E	##	IP67
<b>Product</b>	ITD69H02							
<b>Pulse number</b>								
128 <sup>(1)</sup>		128						
256 <sup>(1)</sup>		256						
512		512						
1024		1024						
2048		2048						
4096		4096						
<b>Voltage supply / signals</b>								
5 VDC / TTL level, linedriver				T				
8...26 VDC / HTL level, push-pull				H				
<b>Output signals</b>								
A, A inv, B, B inv					BI			
A, A inv, B, B inv, 0, 0 inv					NI			
<b>Connection</b>								
Cable 1 m, radial						KR1		
<b>Operating temperature</b>								
-40...+100 °C							E	
<b>Through hollow shaft</b>								
$\varnothing 40$ mm								40
$\varnothing 42$ mm								42
$\varnothing 45$ mm								45
$\varnothing 50$ mm								50
$\varnothing 55$ mm								55
$\varnothing 60$ mm								60
$\varnothing 65$ mm								65
$\varnothing 68$ mm								68
<b>Protection</b>								
IP 67								IP67

(1) Featured pulse numbers available as BI output signals.

Other diameters on request