

ITD49H00 - Rectangular signal

Through hollow shaft $\varnothing 8$ to $\varnothing 28$ mm

64...2048 pulses per revolution

Overview

- Bearingless magnetic encoder
- Max. 2048 pulses per revolution
- Output circuits: HTL or TTL
- Fast, easy and space saving installation
- Maintenance-free
- High accuracy - error max. $\pm 0.3^\circ$
- Rotation speed max. 18000 rpm
- High resistance to dirt and vibrations
- Magnetic rotor included in delivery



Picture similar

Technical data

Technical data - electrical ratings

Voltage supply	5 VDC $\pm 5\%$ 8...26 VDC
Reverse polarity protection	Yes
Short-circuit proof	Yes
Consumption w/o load	≤ 50 mA
Pulses per revolution	64 ... 2048
Interpolation	1-fold (single) 2-fold 4-fold 8-fold 16-fold 32-fold
Output signals	A 90° B + inverted A 90° B, N + inverted
Output stages	TTL linedriver (short-circuit proof) HTL push-pull (short-circuit proof)
Output current	≤ 30 mA
Output frequency	≤ 300 kHz (TTL) ≤ 160 kHz (HTL)

Technical data - electrical ratings

System accuracy	$\pm 0.3^\circ$
Interference immunity	EN 61000-6-2
Emitted interference	EN 61000-6-3

Technical data - mechanical design

Shaft type	$\varnothing 8 \dots 28$ mm (through hollow shaft)
Dimensions (sensor head)	12 x 16 x 49 mm
Protection EN 60529	IP 67 (relating to sealed electronics)
Operating speed	≤ 18000 rpm
Working distance	0.2 ... 0.5 mm (radial), optimal 0,3 mm
Axial offset	± 0.5 mm
Material	Housing: plastic Shaft: stainless steel 1.4104
Operating temperature	$-40 \dots +100$ °C (fixed cable)
Resistance	EN 60068-2-6 Vibration 10 g, 55-2000 Hz EN 60068-2-27 Shock 100 g, 11 ms
Weight approx.	250 g
Connection	Cable 1 m

Optional

- Cable with connector
- Redundant sensing

ITD49H00 - Rectangular signal

Through hollow shaft $\varnothing 8$ to $\varnothing 28$ mm

64...2048 pulses per revolution

Terminal assignment

With BI-signals, cable [4x2x0,08 mm²]

Core colour	Assignment
green	Track A
yellow	Track A inv.
grey	Track B
pink	Track B inv.
red	UB
blue	GND
transparent	Shield/Housing

With NI-signals, cable [4x2x0,08 mm²]

Core colour	Assignment
green	Track A
yellow	Track A inv.
grey	Track B
pink	Track B inv.
brown	Track N
white	Track N inv.
red	UB
blue	GND
transparent	Shield/Housing

Output signals

Clockwise rotation when looking at the mounting side.

BI-Output signals

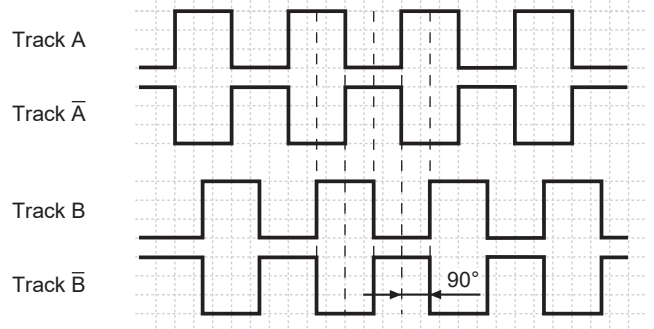

NI-Output signals

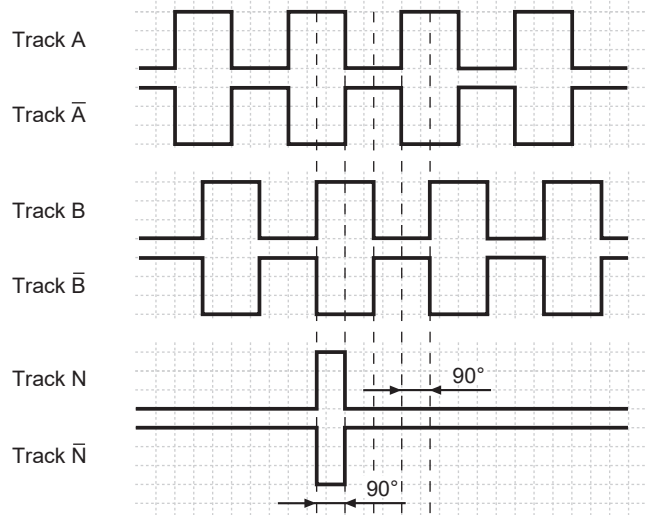

Trigger level

Outputs	Linedriver
Output level High	$\geq 2,5$ V
Output level Low	$\leq 0,5$ V
Load	≤ 30 mA

Outputs	Push-pull short-circuit proof
Output level High	$\geq UB - 3$ V
Output level Low	$\leq 1,5$ V
Load	≤ 30 mA

ITD49H00 - Rectangular signal

Through hollow shaft $\varnothing 8$ to $\varnothing 28$ mm

64...2048 pulses per revolution

Dimensions

mounting side (proposition)

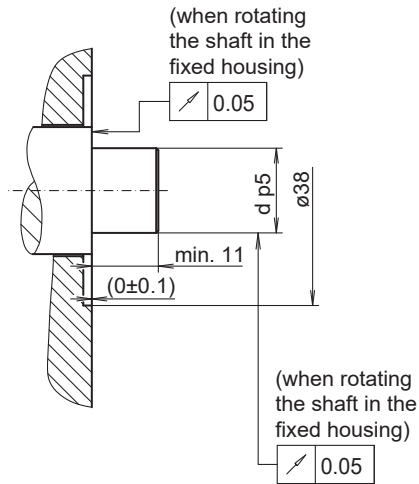

dimension drawing (optimal mounting)

$d = \varnothing 9$ mm, $\varnothing 9.525$ mm, $\varnothing 10$ mm, $\varnothing 12$ mm, $\varnothing 12.7$ mm, $\varnothing 14$ mm, $\varnothing 15$ mm, $\varnothing 15.875$ mm, $\varnothing 19$ mm, $\varnothing 25$ mm, $\varnothing 25.4$ mm, $\varnothing 28$ mm.
Please specify the desired bore diameter in your order.

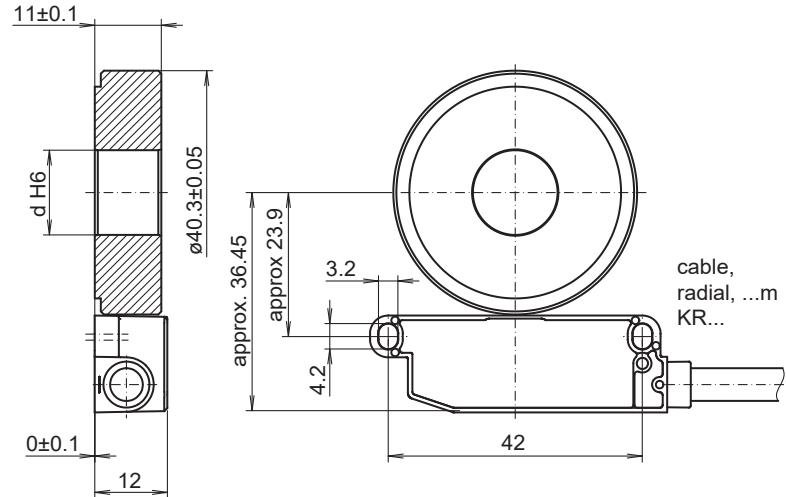

$d = \varnothing 8$ mm

Please specify the desired bore diameter in your order.

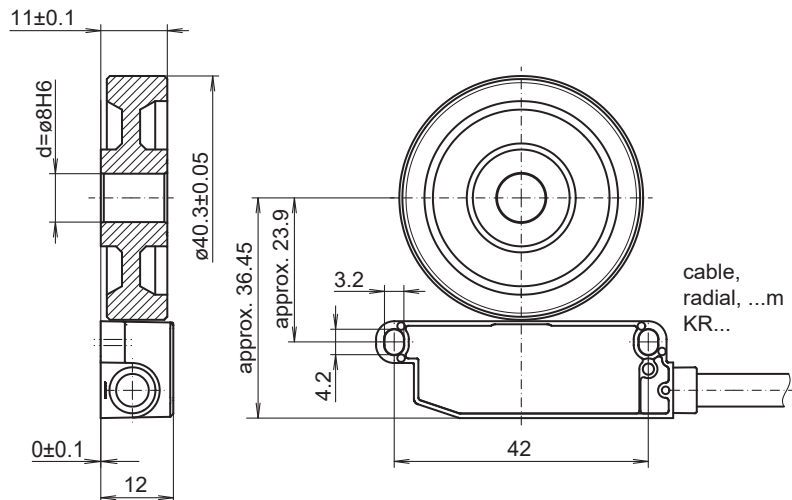

Mounting type	Shaft tolerance	Requirement
Shrink fitting	d p5	Maximale Erwärmung des Polrades $T_{(max)} = 100$ °C
Adhesive mounting	d g6	Please observe the manufacturer's instructions for the adhesive mounting with respect to adhesives and adhesive air gap. Recommendation: Adhesive Loctite 3504

Installation note:

The system, consisting of sensor and rotor, form a matched pair. They may not be exchanged individually. The sensor should be mounted on an electrically conductive surface on potting side.

ITD49H00 - Rectangular signal

Through hollow shaft $\varnothing 8$ to $\varnothing 28$ mm

64...2048 pulses per revolution

Dimensions

Mounting tolerances, operating tolerances

Permitted change of position sensor to rotor during mounting and operation:

Axial offset:

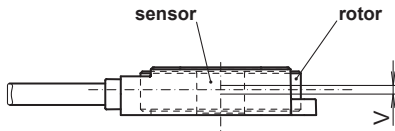

$V = \pm 0.5$ mm, optimal 0.1 mm

Working distance:

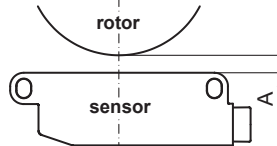

$A = 0.2 \dots 0.5$ mm,
optimal 0.3 mm

Use the distance band as a mounting tool for optimal gap (0.3 mm) between sensor and rotor.

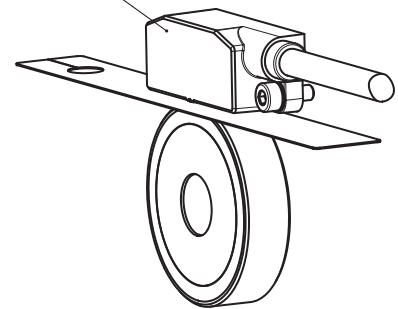

Mounting position

Mounting position (1-1) sensor to rotor should not be altered!

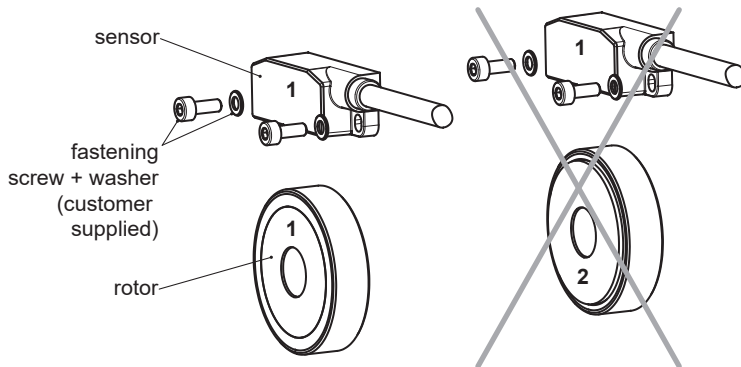

ITD49H00 - Rectangular signal

 Through hollow shaft $\varnothing 8$ to $\varnothing 28$ mm

64...2048 pulses per revolution

Ordering reference

		ITD49H00	#####	#	####	KR1	E	#####	IP	67
Product		ITD49H00								
		ITD49H00								
Pulse number										
	64 ⁽¹⁾		64							
	128 ⁽¹⁾		128							
	256		256							
	512		512							
	1024		1024							
	2048		2048							
Voltage supply										
	UB= 5 VDC \pm 5% / TTL level, linedriver						T			
	UB= 8...26 VDC / HTL level, push-pull						H			
Output signal										
	A, A inv, B, B inv						BI			
	A, A inv, B, B inv, N, N inv						NI			
Connection										
	Cable radial, 1.00 m						KR1			
Operating temperature										
	-40...+100 °C (fixed cable)						E			
Magnetic wheel H00										
	$\varnothing 8$ mm, for adhesive or heat-shrink mounting							08		
	$\varnothing 9$ mm, for adhesive or heat-shrink mounting							09		
	$\varnothing 10$ mm, for adhesive or heat-shrink mounting							10		
	$\varnothing 12$ mm, for adhesive or heat-shrink mounting							12		
	$\varnothing 14$ mm, for adhesive or heat-shrink mounting							14		
	$\varnothing 15$ mm, for adhesive or heat-shrink mounting							15		
	$\varnothing 19$ mm, for adhesive or heat-shrink mounting							19		
	$\varnothing 25$ mm, for adhesive or heat-shrink mounting							25		
	$\varnothing 28$ mm, for adhesive or heat-shrink mounting							28		
	IP								IP	
Protection class										
	IP67 (relating to sealed electronics)									67

(1) Featured pulse numbers available as BI output signals.

Other diameters on request