

HOG890

Incremental HeavyDuty encoders with three switches for demanding machinery and asynchronous drives

Overview

- Protection IP66
- Shaft insulation 3.5 kV
- Corrosion protection CX
- Operating temperature -40...+100 °C
- Cable length up to 350 m (HTL-P)
- Sealed and user-friendly field termination
- Extended protection circuit
- Parameterization
- Standstill, speed, direction and status monitoring and display with Baumer Sensor Suite or using the switches



Picture similar



1+1=1
Combination

Technical data

Technical data - electrical ratings

Voltage supply	4.75...30 VDC (Vin = Vout, HTL/TTL)
Consumption w/o load	≤100 mA
Pulses per revolution	1024 (HTL-P) 2048 (HTL-P)
Further pulses per revolution	Freely parameterizable with Baumer Sensor Suite
Phase shift	Typ. 90 °
Duty cycle	Typ. 50 %
Reference signal	Zero pulse, width 90° or 180°
Sensing method	Optical
Output frequency	≤200 kHz
Output signals	K1, K2, K0 + inverted
Output stages	HTL-P (power linedriver) TTL
Shaft insulation	Suitable up to 3.5 kV
Transmission length	≤350 m at 100 kHz (HTL-P) ≤550 m at 100 kHz (TTL)
Interference immunity	EN 61000-6-2
Emitted interference	EN 61000-6-4
Approval	CE UL approval / E217823 CSA

Technical data - mechanical design

Size (flange)	ø90 mm, length 72 mm
Shaft type	ø12G7 mm (blind hollow shaft) ø16G7 mm (blind hollow shaft) ø11 x 30 mm (solid shaft with key)
Admitted shaft load	≤350 N axial ≤450 N radial
Mounting type	Hollow shaft: central screw Solid shaft: EURO flange B10

Technical data - mechanical design

Protection EN 60529	IP 66
Operating speed	≤6000 rpm (mechanical)
Operating torque	≤6 Ncm
Rotor moment of inertia	160 gcm ²
Material	Housing: aluminium, powder-coated Shaft: stainless steel
Operating temperature	-40...+100 °C
Resistance	IEC 60068-2-6 Vibration 20 g, 10-2000 Hz IEC 60068-2-27 Shock 300 g, 6 ms 1 Mio. brake shocks
Corrosion protection	IEC 60068-2-52 Salt mist for ambient conditions CX according to ISO 12944-2
Connection	Terminal box with pluggable push in terminal blocks and cable gland M20

Technical data - digital switches

Function	Combination with three digital switches: <ul style="list-style-type: none"> • Overspeed and underspeed detection • Standstill and creep monitoring • Direction of rotation display • Warning or failure events • Parameterizable with Baumer Sensor Suite
Switching outputs	Output (Push)
Number of switching outputs	3

Technical data - digital speed switches

Function	Detection of overspeed and underspeed
Max. number of switching outputs	3

HOG890

Incremental HeavyDuty encoders with three switches for demanding machinery and asynchronous drives

Technical data

Technical data - digital speed switches

Parametrization	Speed range
	Hysteresis
	Switching delay
Speed setting resolution	0.1 rpm
Switching accuracy	± 2 % (up to ±1 rpm at 50 rpm)

Technical data - standstill monitoring

Function	Detection of standstill and creep
Max. number of switching outputs	1

Technical data - standstill monitoring

Parametrization	Dwell time
	Standstill position window
Activation Speed	±2 rpm

Technical data - direction of rotation

Function	Detection and display of the direction of rotation
Max. number of switching outputs	1
Parametrization	Hysteresis

Optional

- ATEX

HOG890

Incremental HeavyDuty encoders with three switches for demanding machinery and asynchronous drives

Baumer Sensor Suite

Monitoring

The following information is displayed with the Baumer Sensor Suite:

- Encoder settings
- Speed and position over time
- Current speed, position and temperature
- Encoder status
- Minimum and maximum temperature over entire service life
- Total operating time
- Total revolutions
- Switch monitoring
 - Switch status
 - Speed over time per switch with switching window
 - Switch status over time
 - Direction of rotation status
 - Status of standstill monitoring

Parameterization

The following parameters can be set via USB-C access with the Baumer Sensor Suite:

- Number of lines per mechanical revolution
- Output stages
- Reference length and phase
- Setting the user units
- Switching outputs
 - Switching active high, active low
 - Speed switch
 - Direction of rotation switch
 - Standstill switch
- Time behavior for switching outputs
 - Minimum switch-on time (On)
 - Minimum switch-off duration (Off)

Parameterization - encoder

Pulses per revolution	Selection: 50, 500, 512, 1000, 1024, 2048, 2500, 4096, 5000 + free input
Output stages	HTL-P (power linedriver) TTL
Rotating direction	CW, CCW
Width of zero pulse	90°, 180° (reference signal)

Parameterization - digital switches

Min. switch-on time	1...1000 ms
Min. switch-off time	1...1000 ms

Parameterization - digital speed switch

Function	Speed switch with adjustable speed limits and switching delay to filter out short-term speed peaks
Switching output	Active high / active low
Upper/lower speed range	±2 ... 6000 rpm
Hysteresis	0...50 %
Switching delay time	0...5000 ms (0 ms default)

Parameterization - standstill monitoring

Function	Reliable creep detection through position monitoring if the speed falls below a specified speed within a defined time window
Switching output	Active high / active low
Dwell time	10...1000000 ms
Creep Window	1...100°

Parameterization - direction of rotation

Function	Direction detection with adjustable hysteresis
Switching output	Active high / active low
Hysteresis	1...100°

HOG890

Incremental HeavyDuty encoders with three switches for demanding machinery and asynchronous drives

Terminal assignment

Push output

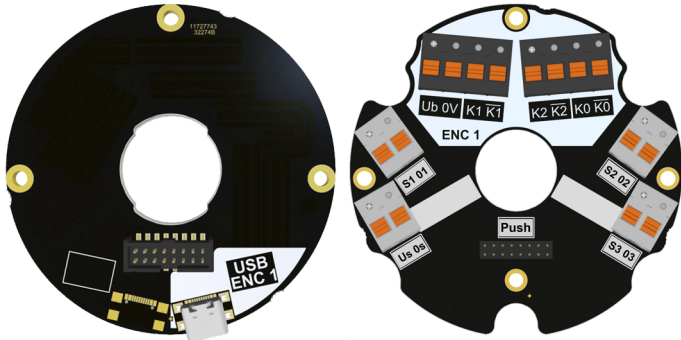

Terminal significance

U_b	Voltage supply - encoder 1
0V	Ground - encoder 1
K0	Zero pulse (reference signal) - encoder 1
$\bar{K}0$	Zero pulse inverted - encoder 1
K1	Output signal channel 1 - encoder 1
$\bar{K}1$	Output signal channel 1 inverted - encoder 1
K2	Output signal channel 2 - encoder 1
$\bar{K}2$	Output signal channel 2 inverted - encoder 1
U_s	Voltage supply - push output
0s	Ground - push output
S1	Push switching output 1
S2	Push switching output 2
S3	Push switching output 3
01	Ground - push output 1
02	Ground - push output 2
03	Ground - push output 3
USB ENC1	USB-C for parameterization

Output signals

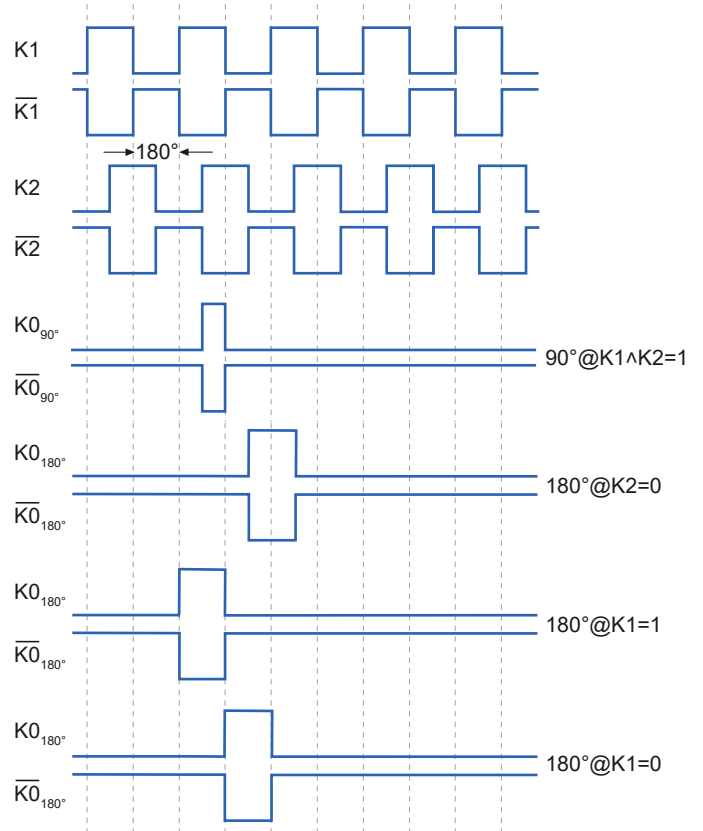

With positive direction of rotation / clockwise, with view on the encoder shaft

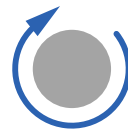

HOG890

Incremental HeavyDuty encoders with three switches for demanding machinery and asynchronous drives

Dimensions

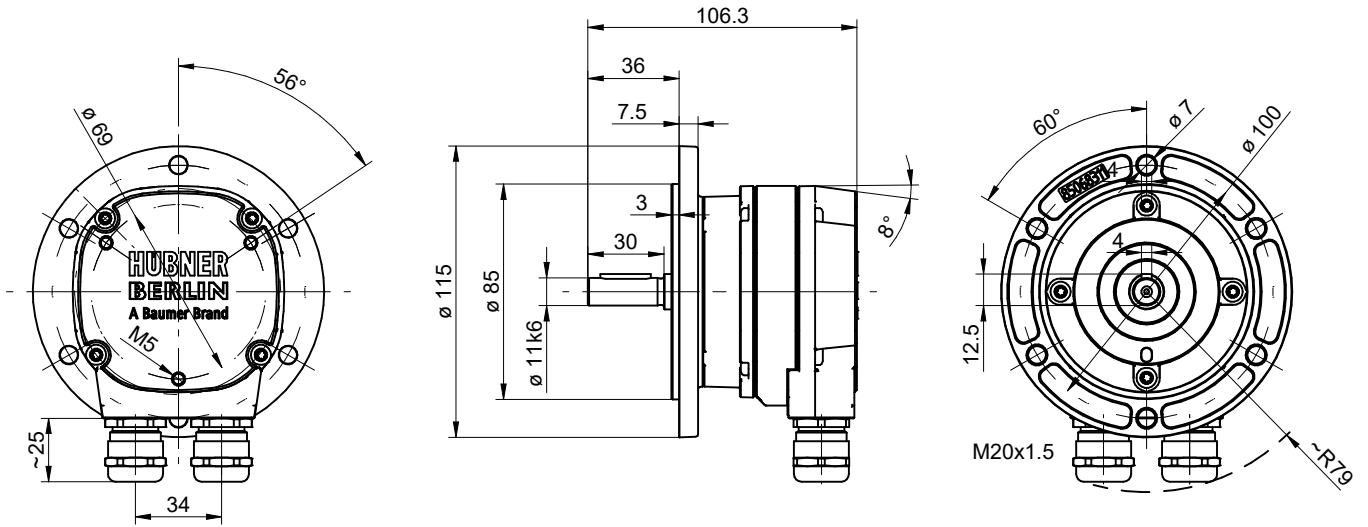

Solid shaft, cable gland

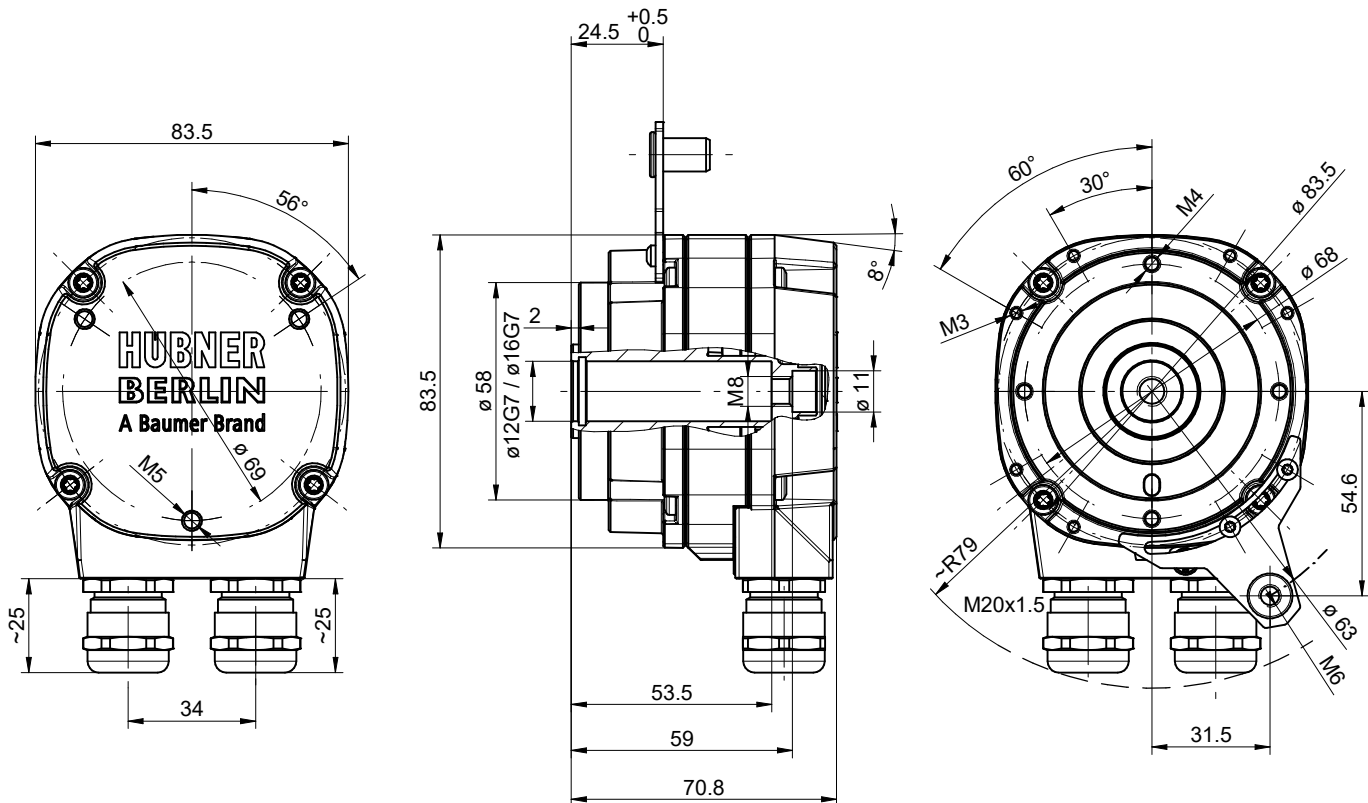

Blind hollow shaft, cable gland (torque plate can be mounted at different positions)

HOG890

Incremental HeavyDuty encoders with three switches for demanding machinery and asynchronous drives

Ordering reference

Product	Shaft	Pulses per revolution, output	Connection	Comment	Material number
HOG890	Solid shaft ø11 mm	Parameterization & monitoring at customer	2 x cable gland M20	3 x push	EHOG890-11730711
	Blind hollow shaft ø12G7	Parameterization & monitoring at customer	2 x cable gland M20	3 x push	EHOG890-11730712
	Blind hollow shaft ø16G7	Parameterization & monitoring at customer	2 x cable gland M20	3 x push	EHOG890-11730713