

HOG870

Redundant incremental HeavyDuty encoders for demanding machinery and asynchronous drives

Overview

- Protection IP66
- Shaft insulation 3.5 kV
- Corrosion protection CX
- Operating temperature -40...+100 °C
- Cable length up to 350 m (HTL-P)
- Sealed and user-friendly field termination
- Extended protection circuit
- Parameterization, including different resolutions
- Status monitoring and display with Baumer Sensor Suite

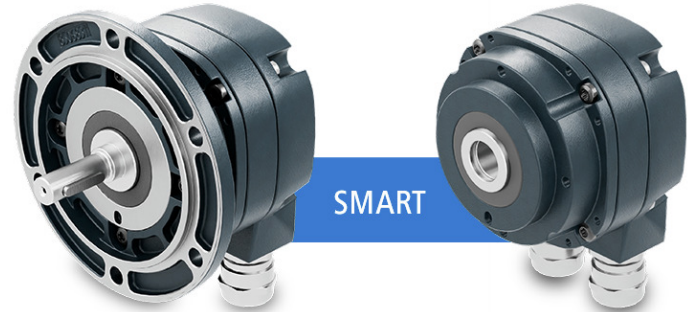

Picture similar



1+1=1
Combination

Technical data

Technical data - electrical ratings

Voltage supply	4.75...30 VDC (Vin = Vout, HTL/TTL)
Consumption w/o load	≤100 mA
Pulses per revolution	1024 (HTL-P) 2048 (HTL-P)
Further pulses per revolution	Further pulse numbers parameterized ex works or freely parameterizable (SMART) with Baumer Sensor Suite
Phase shift	Typ. 90 °
Duty cycle	Typ. 50 %
Reference signal	Zero pulse, width 90° or 180°
Sensing method	Optical
Output frequency	≤200 kHz
Output signals	K1, K2, K0 + inverted
Output stages	HTL-P (power linedriver) TTL
Shaft insulation	Suitable up to 3.5 kV
Transmission length	≤350 m at 100 kHz (HTL-P) ≤550 m at 100 kHz (TTL)
Interference immunity	EN 61000-6-2
Emitted interference	EN 61000-6-4
Approval	CE UL approval / E217823 CSA

Technical data - mechanical design

Size (flange)	ø90 mm, length 72 mm
Shaft type	ø12G7 mm (blind hollow shaft) ø16G7 mm (blind hollow shaft) ø11 x 30 mm (solid shaft with key)
Admitted shaft load	≤350 N axial ≤450 N radial
Mounting type	Hollow shaft: central screw Solid shaft: EURO flange B10
Protection EN 60529	IP 66
Operating speed	≤6000 rpm (mechanical)
Operating torque	≤6 Ncm
Rotor moment of inertia	160 gcm ²
Material	Housing: aluminium, powder-coated Shaft: stainless steel
Operating temperature	-40...+100 °C
Resistance	IEC 60068-2-6 Vibration 20 g, 10-2000 Hz IEC 60068-2-27 Shock 300 g, 6 ms 1 Mio. brake shocks
Corrosion protection	IEC 60068-2-52 Salt mist for ambient conditions CX according to ISO 12944-2
Connection	Terminal box with pluggable push in terminal blocks and cable gland M20

Optional

- Parameterized pulse numbers can be ordered ex works
- ATEX

Terminal assignment

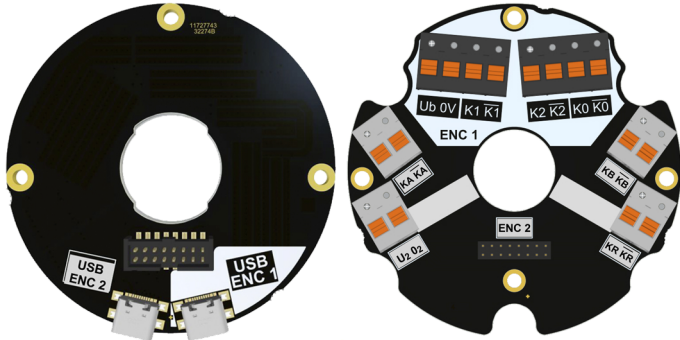

Terminal significance

U _b	Voltage supply - encoder 1
0V	Ground - encoder 1
K0	Zero pulse (reference signal) - encoder 1
$\overline{K0}$	Zero pulse inverted - encoder 1
K1	Output signal channel 1 - encoder 1
$\overline{K1}$	Output signal channel 1 inverted - encoder 1
K2	Output signal channel 2 - encoder 1
$\overline{K2}$	Output signal channel 2 inverted - encoder 1
U2	Voltage supply - encoder 2
02	Ground - encoder 2
KR	Zero pulse (reference signal) - encoder 2
\overline{KR}	Zero pulse inverted - encoder 2
KA	Output signal channel 1 - encoder 2
\overline{KA}	Output signal channel 1 inverted - encoder 2
KB	Output signal channel 2 - encoder 2
\overline{KB}	Output signal channel 2 inverted - encoder 2
USB ENC1	USB-C for parameterization - encoder 1 (SMART)
USB ENC2	USB-C for parameterization - encoder 2 (SMART)

Output signals

Encoder 1

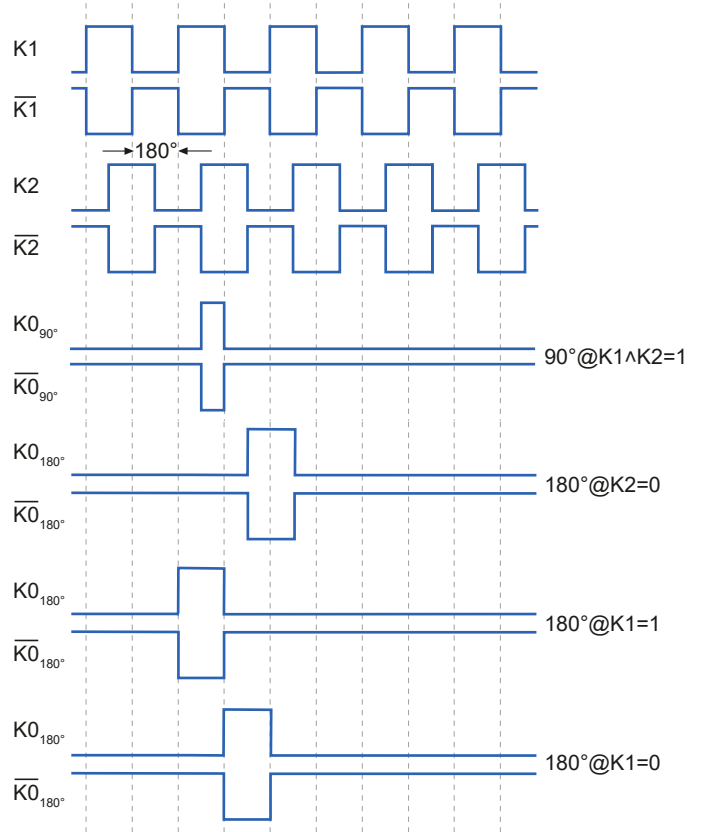

With positive direction of rotation / clockwise, with view on the encoder shaft

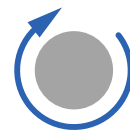

Output signals

Encoder 2

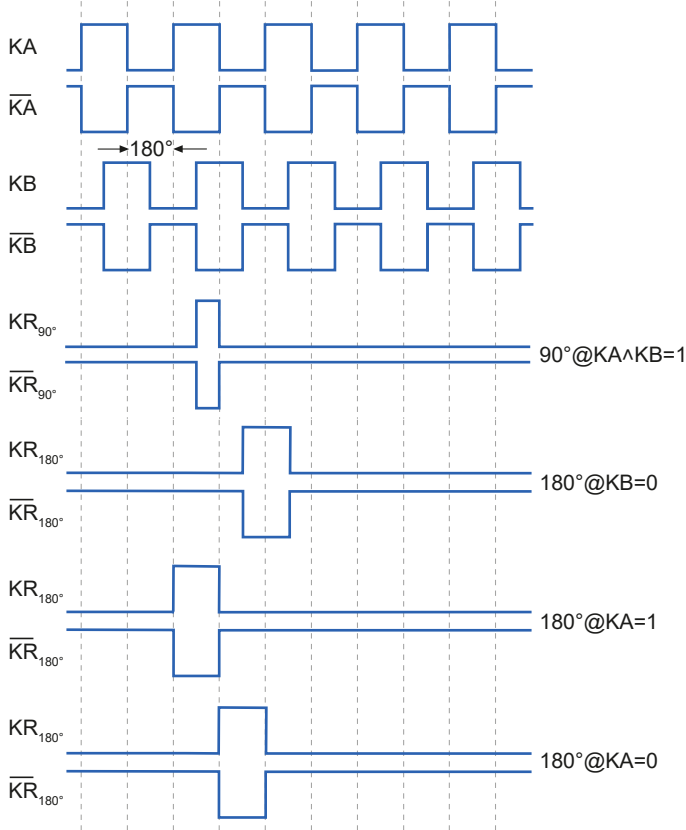

With positive direction of rotation / clockwise, with view on the encoder shaft



HOG870

Redundant incremental HeavyDuty encoders for demanding machinery and asynchronous drives

Dimensions

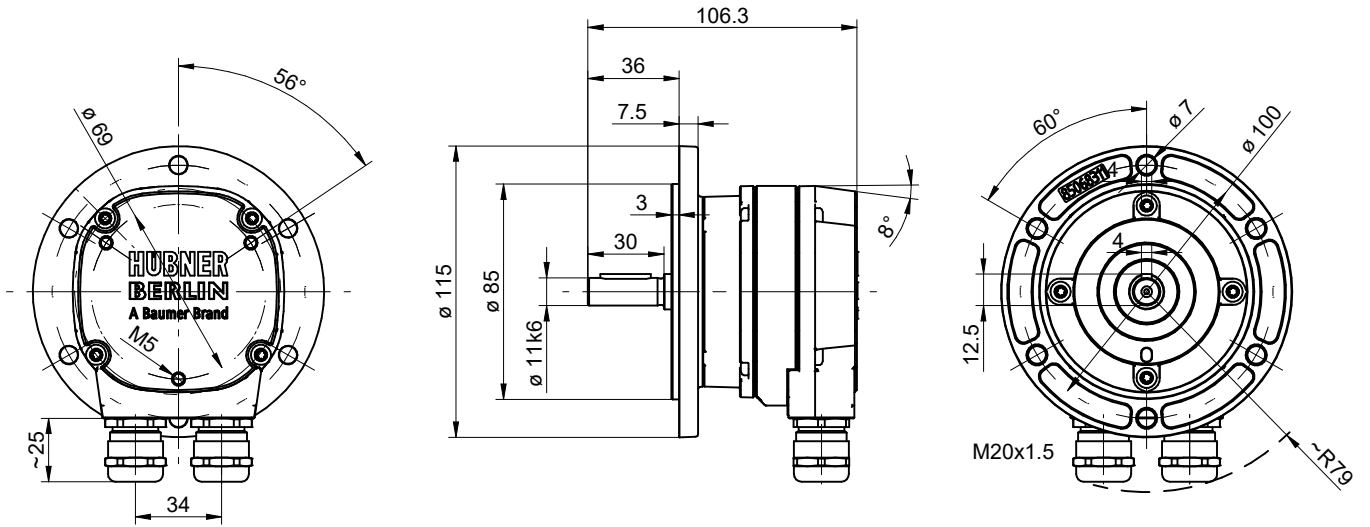

Solid shaft, cable gland

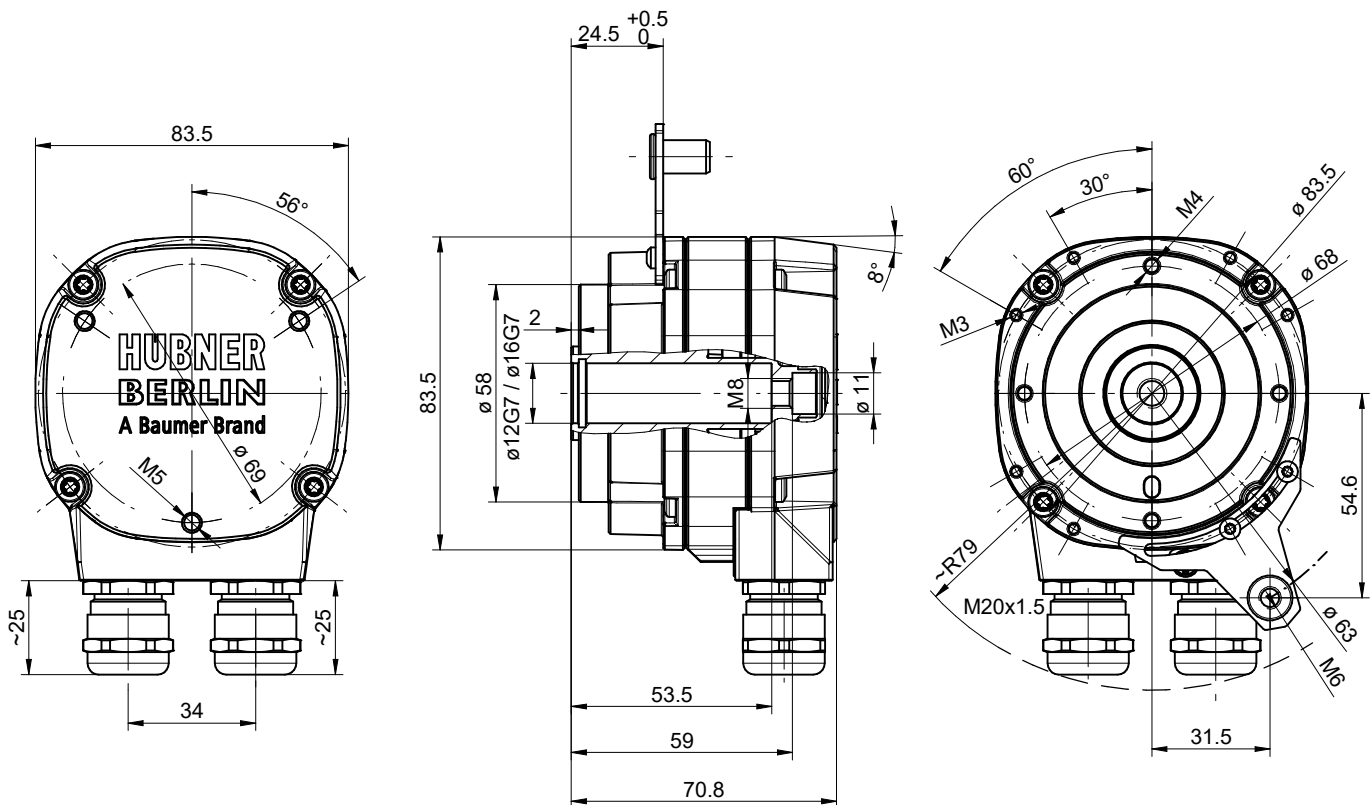

Blind hollow shaft, cable gland (torque plate can be mounted at different positions)

HOG870

Redundant incremental HeavyDuty encoders for demanding machinery and asynchronous drives

Ordering reference

Product	Shaft	Pulses per revolution, output	Connection	Comment	Material number
HOG870	Solid shaft ø11 mm	Parameterization at factory ¹⁾	2 x cable gland M20	Redundant – manipulation proof	EHO870-11730703
		Parameterization & monitoring at customer	2 x cable gland M20	SMART, redundant	EHO870-11730705
	Blind hollow shaft ø12G7	Parameterization at factory ¹⁾	2 x cable gland M20	Redundant – manipulation proof	EHO870-11730706
		Parameterization & monitoring at customer	2 x cable gland M20	SMART, redundant	EHO870-11730707
	Blind hollow shaft ø16G7	Parameterization at factory ¹⁾	2 x cable gland M20	Redundant – manipulation proof	EHO870-11730709
		Parameterization & monitoring at customer	2 x cable gland M20	SMART, redundant	EHO870-11730710

1) Please choose 2x resolution, output stage and zero pulse (length and position) with your order

Resolution: 1...32768 ppr

Output stage: HTL-P or TTL

Zero pulse:

- 90°, K1=K2=1

- 180°, K1=0

- 180°, K2=0

- 180°, K1=1

Example for EHO870-11730703: Encoder 1: 5000 ppr, TTL, 180°, K2=0 / Encoder 2: 1024 ppr, HTL-P, 90°, K1=K2=1