

Overview

- Protection IP66
- Shaft insulation 3.5 kV
- Corrosion protection CX
- Operating temperature -40...+100 °C
- Cable length up to 350 m (HTL-P)
- Sealed and user-friendly field termination
- Extended protection circuit
- Parameterization
- Status monitoring and display with Baumer Sensor Suite

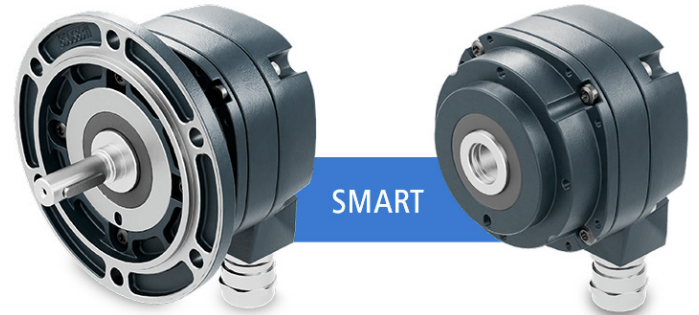

Picture similar



Technical data

Technical data - electrical ratings

Voltage supply	4.75...30 VDC (Vin = Vout, HTL/TTL)
Consumption w/o load	≤100 mA
Pulses per revolution	1024 (HTL-P) 2048 (HTL-P)
Further pulses per revolution	Further pulse numbers parameterized ex works or freely parameterizable (SMART) with Baumer Sensor Suite
Phase shift	Typ. 90 °
Duty cycle	Typ. 50 %
Reference signal	Zero pulse, width 90° or 180°
Sensing method	Optical
Output frequency	≤200 kHz
Output signals	K1, K2, K0 + inverted
Output stages	HTL-P (power linedriver) TTL
Shaft insulation	Suitable up to 3.5 kV
Transmission length	≤350 m at 100 kHz (HTL-P) ≤550 m at 100 kHz (TTL)
Interference immunity	EN 61000-6-2
Emitted interference	EN 61000-6-4
Approval	CE UL approval / E217823 CSA

Technical data - mechanical design

Size (flange)	ø90 mm, length 72 mm
---------------	----------------------

Technical data - mechanical design

Shaft type	ø12G7 mm (blind hollow shaft) ø16G7 mm (blind hollow shaft) ø11 x 30 mm (solid shaft with key) ø17 mm (cone shaft 1:10)
Admitted shaft load	≤350 N axial ≤450 N radial
Mounting type	Hollow shaft: central screw Solid shaft: EURO flange B10
Protection EN 60529	IP 66
Operating speed	≤6000 rpm (mechanical)
Operating torque	≤6 Ncm
Rotor moment of inertia	160 gcm ²
Material	Housing: aluminium, powder-coated Shaft: stainless steel
Operating temperature	-40...+100 °C
Resistance	IEC 60068-2-6 Vibration 20 g, 10-2000 Hz IEC 60068-2-27 Shock 300 g, 6 ms 1 Mio. brake shocks
Corrosion protection	IEC 60068-2-52 Salt mist for ambient conditions CX according to ISO 12944-2
Connection	Terminal box with pluggable push in terminal blocks and cable gland M20 Flange connector M23

Optional

- Parameterized pulse numbers can be ordered ex works
- ATEX

Possible combinations

- Redundant sensing with second output (HOG870)
- Speed monitoring (HOG890)

Terminal assignment

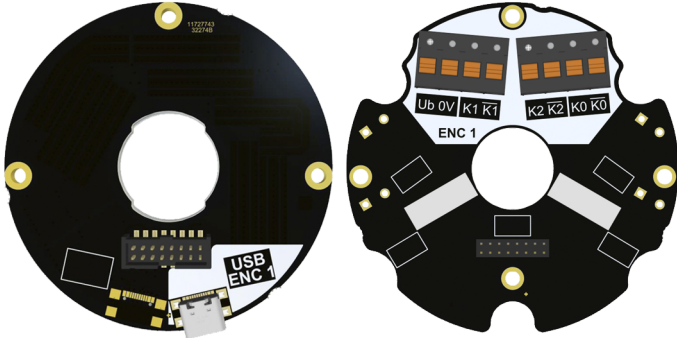

Terminal significance

U_b	Voltage supply - encoder 1
0V	Ground - encoder 1
K0	Zero pulse (reference signal) - encoder 1
$\overline{K0}$	Zero pulse inverted - encoder 1
K1	Output signal channel 1 - encoder 1
$\overline{K1}$	Output signal channel 1 inverted - encoder 1
K2	Output signal channel 2 - encoder 1
$\overline{K2}$	Output signal channel 2 inverted - encoder 1
USB ENC1 USB-C for parameterization encoder 1 (SMART)	

Output signals

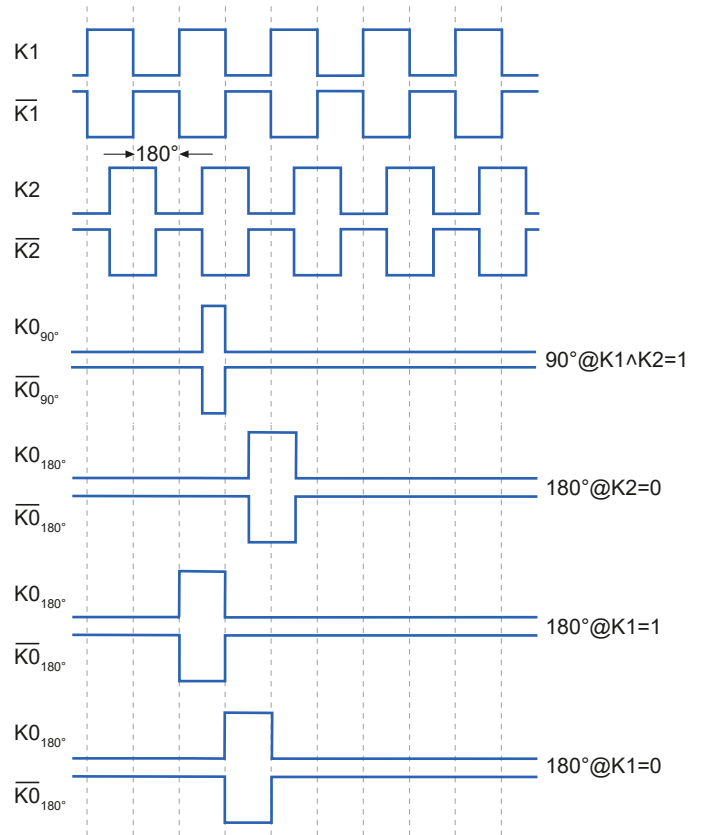

With positive direction of rotation / clockwise, with view on the encoder shaft

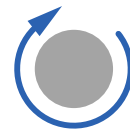

HOG860

High-performant incremental HeavyDuty encoders for demanding machinery and asynchronous drives

Dimensions

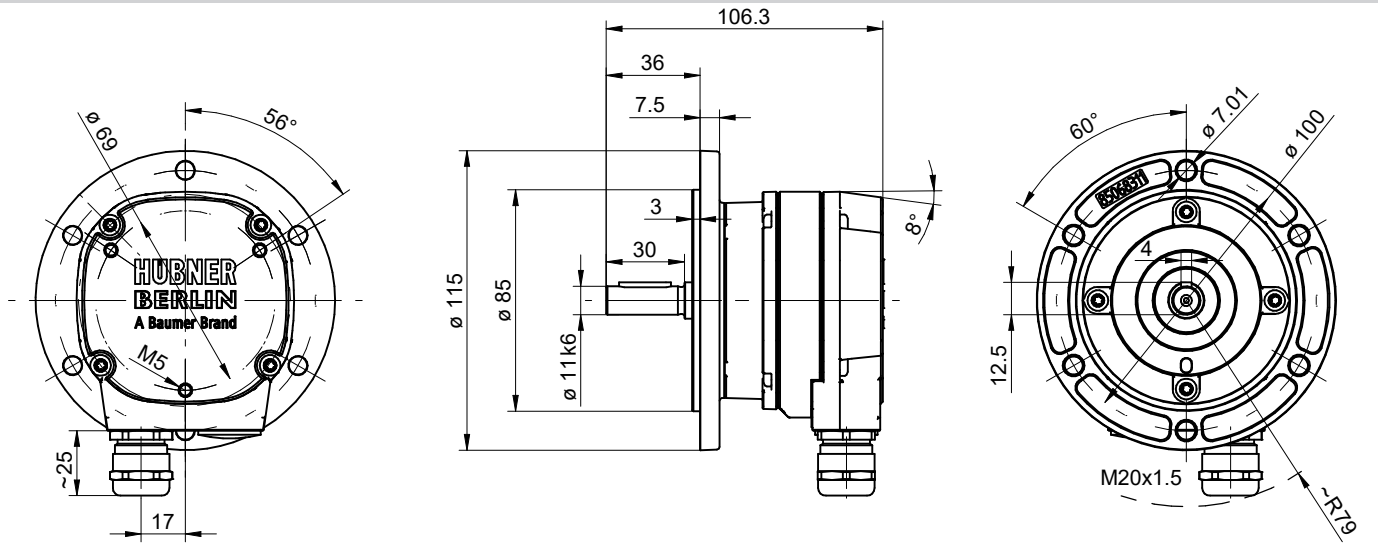

Solid shaft, cable gland

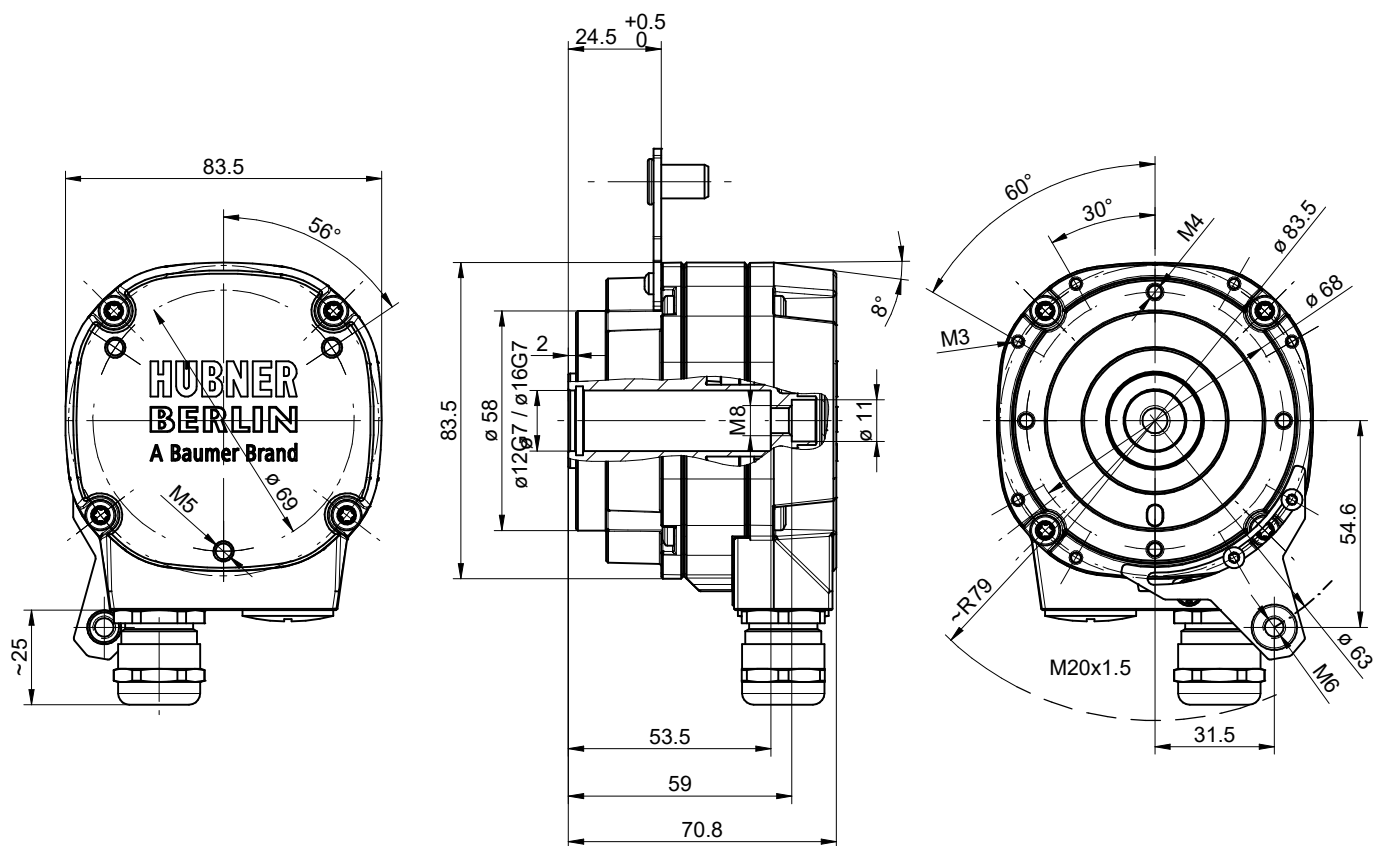

Blind hollow shaft, cable gland (torque plate can be mounted at different positions)

HOG860

High-performant incremental HeavyDuty encoders for demanding machinery and asynchronous drives

Ordering reference					
Product	Shaft	Pulses per revolution, output	Connection	Comment	Material number
HOG860	Solid shaft ø11 mm	1024, HTL	1 x cable gland M20	Manipulation proof	EHOG860-11730669
			1 x flange connector M23	Manipulation proof	EHOG860-11730670
		2048, HTL	1 x cable gland M20	Manipulation proof	EHOG860-11730672
			1 x flange connector M23	Manipulation proof	EHOG860-11730673
		Parameterization at factory ¹⁾	1 x cable gland M20	Manipulation proof	EHOG860-11730674
			1 x flange connector M23	Manipulation proof	EHOG860-11730675
		Parameterization & monitoring at customer	1 x cable gland M20	SMART	EHOG860-11730676
			1 x flange connector M23	SMART	EHOG860-11730677
	Blind hollow shaft ø12G7	1024, HTL	1 x cable gland M20	Manipulation proof	EHOG860-11730678
			1 x flange connector M23	Manipulation proof	EHOG860-11730679
		2048, HTL	1 x cable gland M20	Manipulation proof	EHOG860-11730680
			1 x flange connector M23	Manipulation proof	EHOG860-11730681
		Parameterization at factory ¹⁾	1 x cable gland M20	Manipulation proof	EHOG860-11730682
			1 x flange connector M23	Manipulation proof	EHOG860-11730683
		Parameterization & monitoring at customer	1 x cable gland M20	SMART	EHOG860-11730684
			1 x flange connector M23	SMART	EHOG860-11730685
	Blind hollow shaft ø16G7	1024, HTL	1 x cable gland M20	Manipulation proof	EHOG860-11730686
			1 x flange connector M23	Manipulation proof	EHOG860-11730687
		2048, HTL	1 x cable gland M20	Manipulation proof	EHOG860-11730688
			1 x flange connector M23	Manipulation proof	EHOG860-11730689
		Parameterization at factory ¹⁾	1 x cable gland M20	Manipulation proof	EHOG860-11730690
			1 x flange connector M23	Manipulation proof	EHOG860-11730691
		Parameterization & monitoring at customer	1 x cable gland M20	SMART	EHOG860-11730692
			1 x flange connector M23	SMART	EHOG860-11730693
Cone shaft ø17	1024, HTL	1 x cable gland M20	Manipulation proof	EHOG860-11730694	
		1 x flange connector M23	Manipulation proof	EHOG860-11730695	
	2048, HTL	1 x cable gland M20	Manipulation proof	EHOG860-11730696	
		1 x flange connector M23	Manipulation proof	EHOG860-11730697	
	Parameterization at factory ¹⁾	1 x cable gland M20	Manipulation proof	EHOG860-11730698	
		1 x flange connector M23	Manipulation proof	EHOG860-11730699	
	Parameterization & monitoring at customer	1 x cable gland M20	SMART	EHOG860-11730701	
		1 x flange connector M23	SMART	EHOG860-11730702	

1) Please choose resolution, output stage and zero pulse (length and position) with your order

Resolution: 1...32768 ppr

Output stage: HTL-P or TTL

Zero pulse:

- 90°, K1=K2=1

- 180°, K1=0

- 180°, K2=0

- 180°, K1=1

Example for EHOG860 - 11730674: 5000 ppr, TTL, 180°, K2=0