

HOG840

Economical, incremental HeavyDuty encoders for wind turbines and machinery

Overview

- Protection IP66
- Shaft insulation 3.5 kV
- Corrosion protection C4
- Operating temperature -30...+85 °C
- Cable length up to 200 m (HTL-P)
- Sealed and user-friendly field termination

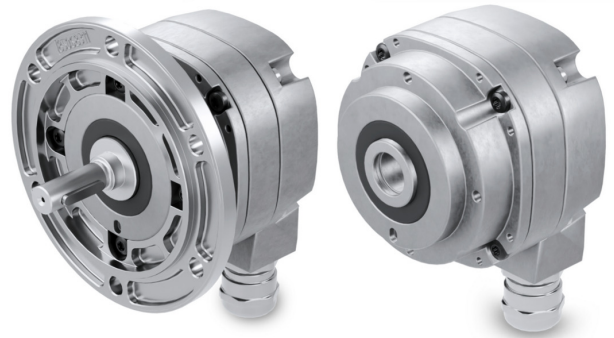

Picture similar

HUBNER
BERLIN
A Baumer Brand



HeavyDuty
70 years of experience

Technical data

Technical data - electrical ratings

Voltage supply	4.75...30 VDC (Vin = Vout, HTL/TTL)
Consumption w/o load	≤100 mA
Pulses per revolution	1024 (HTL-P) 2048 (HTL-P)
Further pulses per revolution	Further pulse numbers parameterized ex works
Phase shift	Typ. 90 °
Duty cycle	Typ. 50 %
Reference signal	Zero pulse, width 90°
Sensing method	Optical
Output frequency	≤200 kHz
Output signals	K1, K2, K0 + inverted
Output stages	HTL-P (power linedriver) TTL
Shaft insulation	Suitable up to 3.5 kV
Transmission length	≤200 m at 100 kHz (HTL-P) ≤400 m at 100 kHz (TTL)
Interference immunity	EN 61000-6-2
Emitted interference	EN 61000-6-4
Approval	CE UL approval / E217823 CSA

Technical data - mechanical design

Size (flange)	ø90 mm, length 72 mm
Shaft type	ø12G7 mm (blind hollow shaft) ø16G7 mm (blind hollow shaft) ø11 x 30 mm (solid shaft with key)
Admitted shaft load	≤350 N axial ≤450 N radial
Mounting type	Hollow shaft: central screw Solid shaft: EURO flange B10
Protection EN 60529	IP 66
Operating speed	≤6000 rpm (mechanical)
Operating torque	≤6 Ncm
Rotor moment of inertia	160 gcm ²
Material	Housing: aluminium Shaft: stainless steel
Operating temperature	-30...+85 °C
Resistance	IEC 60068-2-6 Vibration 20 g, 10-2000 Hz IEC 60068-2-27 Shock 300 g, 6 ms 1 Mio. break shocks
Corrosion protection	IEC 60068-2-52 Salt mist for ambient conditions C4 according to ISO 12944-2
Connection	Terminal box with pluggable push in terminal blocks and cable gland M20

The product features and technical data specified do not express or imply any warranty. Technical modifications subject to change.

Terminal assignment

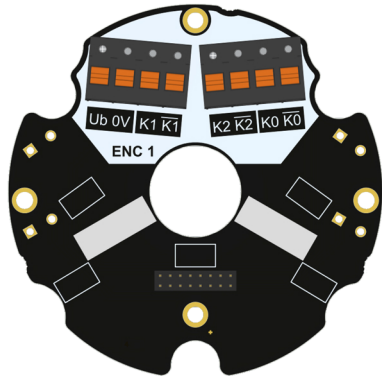

Terminal significance

U_b	Voltage supply - encoder 1
0V	Ground - encoder 1
K0	Zero pulse (reference signal) - encoder 1
$\overline{K0}$	Zero pulse inverted - encoder 1
K1	Output signal channel 1 - encoder 1
$\overline{K1}$	Output signal channel 1 inverted - encoder 1
K2	Output signal channel 2 - encoder 1
$\overline{K2}$	Output signal channel 2 inverted - encoder 1

Output signals

HTL/TTL

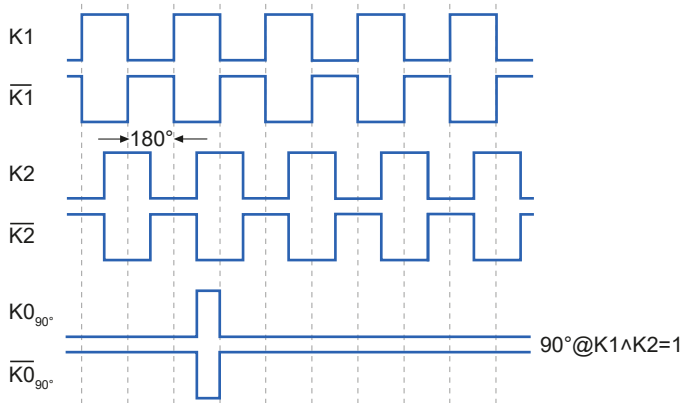

With positive direction of rotation / clockwise, with view on the encoder shaft



HOG840

Economical, incremental HeavyDuty encoders for wind turbines and machinery

Dimensions

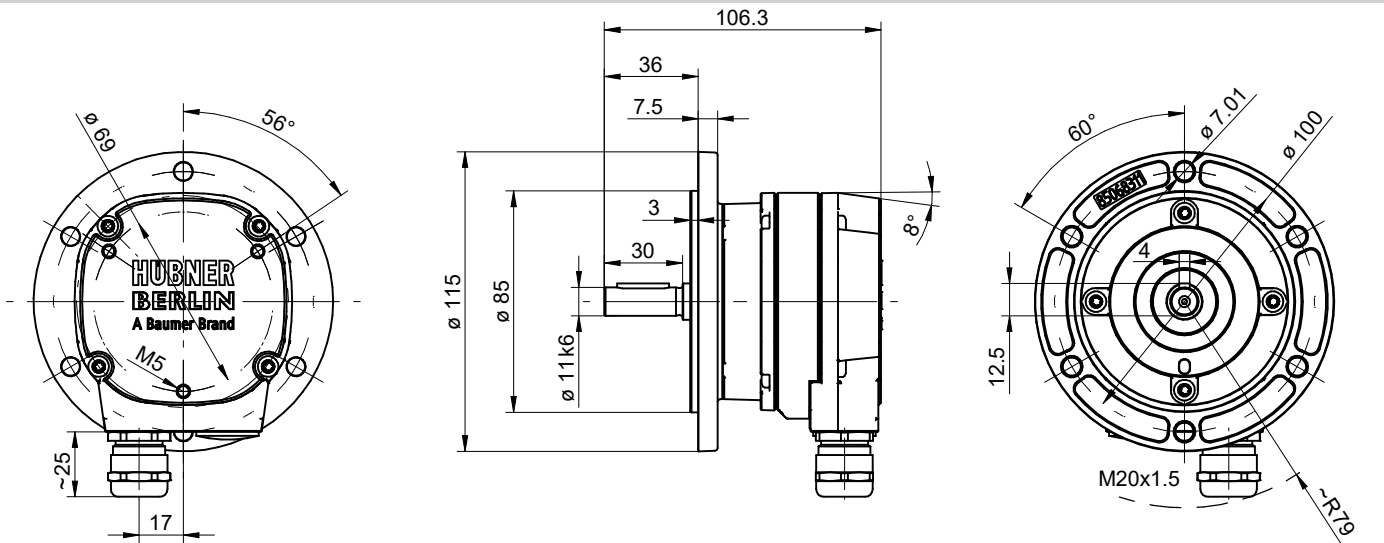

Solid shaft, cable gland

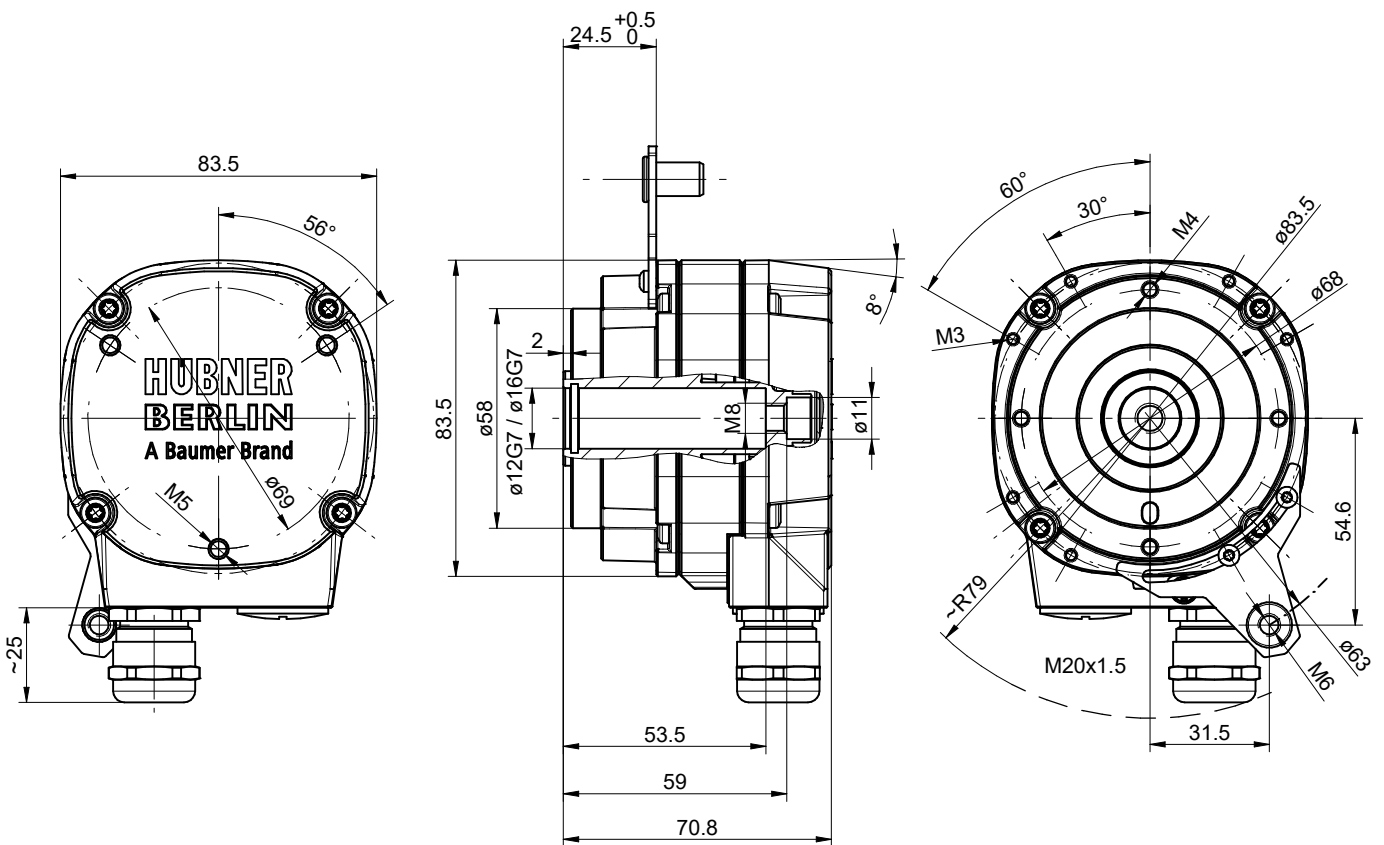

HOG840 - blind hollow shaft, cable gland

HOG840

Economical, incremental HeavyDuty encoders for wind turbines and machinery

Ordering reference

Product	Shaft	Pulses per revolution, output	Connection	Material number
HOG840	Solid shaft ø11 mm	1024, HTL	1 x cable gland M20	EHOG840-11730613
		2048, HTL	1 x cable gland M20	EHOG840-11730659
		Parameterization at factory ¹⁾	1 x cable gland M20	EHOG840-11730660
	Blind hollow shaft ø12G7	1024, HTL	1 x cable gland M20	EHOG840-11730661
		2048, HTL	1 x cable gland M20	EHOG840-11730662
		Parameterization at factory ¹⁾	1 x cable gland M20	EHOG840-11730663
	Blind hollow shaft ø16G7	1024, HTL	1 x cable gland M20	EHOG840-11730664
		2048, HTL	1 x cable gland M20	EHOG840-11730665
		Parameterization at factory ¹⁾	1 x cable gland M20	EHOG840-11730666

1) Please choose resolution, output stage and zero pulse (length and position) with your order

Resolution: 1...32768 ppr

Output stage: HTL-P or TTL

Zero pulse:

- 90°, K1=K2=1

- 180°, K1=0

- 180°, K2=0

- 180°, K1=1

Example for EHOG840 - 11730660: 5000 ppr, TTL, 180°, K2=0