

# HOG10 DN 1024 I LR 16H7 + FSL4

Encoder with integrated centrifugal switch, blind hollow shaft, 1024 pulses per revolution

Article number: 11075609

## Overview

- HTL output driver for cable length up to 350 m
- Mechanical speed monitoring based on centrifugal force
- Double-side bearing with hybrid bearing for extended service life
- Terminal boxes, turn by 180°
- High resistance to shock and vibrations
- Sealing system for dusty environment



## Technical data

### Technical data - electrical ratings (encoder)

Voltage supply	9...30 VDC
Consumption w/o load	≤100 mA
Pulses per revolution	1024
Phase shift	90 ° ±20°
Duty cycle	40...60 %
Reference signal	Zero pulse, width 90°
Output frequency	≤120 kHz
Output signals	K1, K2, K0 + inverted
Output stages	HTL-P (power linedriver)
Sensing method	Optical

### Technical data - electrical ratings (centrifugal switch)

Switching accuracy	± 4 % ( $\Delta n = 2$ rpm/s); 20 % ( $\Delta n = 1500$ rpm/s)
Switching deviation	≤3 % (cw-ccw rotation)
Switching hysteresis	40 % of switching speed
Switching outputs	1 output, speed control
Output switching capacity	≤6 A / 230 VAC; ≤1 A / 125 VDC (EAC: <50 VAC / 75 VDC)
Minimum switching current	50 mA

### Technical data - mechanical design

Size (flange)	ø105 mm
Shaft type	ø16 mm (blind hollow shaft)
Admitted shaft load	≤450 N axial ≤600 N radial
Protection EN 60529	IP 66
Range of switching speed (ns)	1100...1299 rpm ( $\Delta n = 2$ rpm/s)
Operating torque typ.	6 Ncm
Rotor moment of inertia	400 gcm <sup>2</sup>
Material	Housing: aluminium die-cast Shaft: stainless steel
Operating temperature	-40...+100 °C
Resistance	IEC 60068-2-6 Vibration 5 g, 10-2000 Hz IEC 60068-2-27 Shock 50 g, 11 ms
Corrosion protection	IEC 60068-2-52 Salt mist for ambient conditions C4 according to ISO 12944-2
Connection	2x terminal box
Weight approx.	2.2 kg

# HOG10 DN 1024 I LR 16H7 + FSL4

Encoder with integrated centrifugal switch, blind hollow shaft, 1024 pulses per revolution

Article number: 11075609

## General information

The constructive design of the centrifugal switch is its use as a switch with positive break function. It must not be used as a continuous switch (switching cycles greater than 500 during service life).

## Terminal assignment

### View A (see dimension)

Connecting terminal terminal box encoder

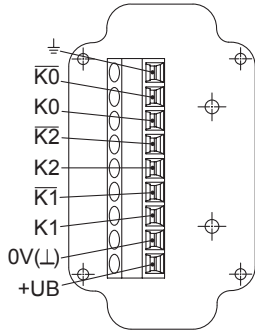

### Option EMS: View A (see dimension)

Connecting terminal terminal box encoder

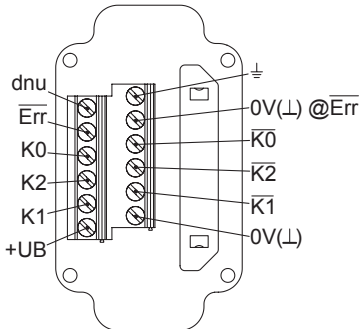

### View B (see dimension)

Connecting terminal centrifugal switch

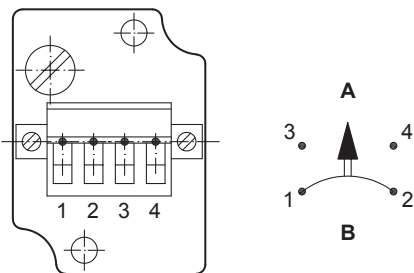

**A** = make contact, **B** = break contact

## Terminal significance

### Encoder incremental

+UB	Voltage supply
0V (L)	Ground
⊥	Earth ground (housing)
K1	Output signal channel 1
$\overline{K1}$	Output signal channel 1 inverted
K2	Output signal channel 2 (offset by 90° to channel 1)
$\overline{K2}$	Output signal channel 2 inverted
K0	Zero pulse (reference signal)
$\overline{K0}$	Zero pulse inverted
$\overline{Err}$	Error output (option EMS)
dnu	Do not use

## Output signals

### HTL/TTL

At positive rotating direction (see dimension)

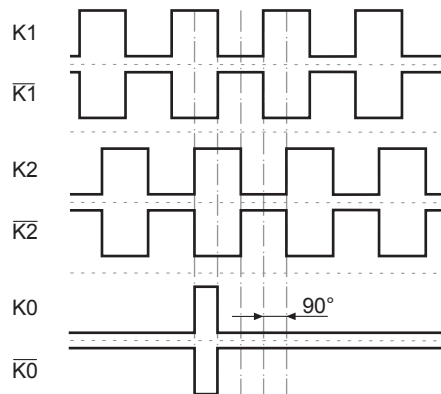

# HOG10 DN 1024 I LR 16H7 + FSL4

Encoder with integrated centrifugal switch, blind hollow shaft, 1024 pulses per revolution

Article number: 11075609

## Dimensions

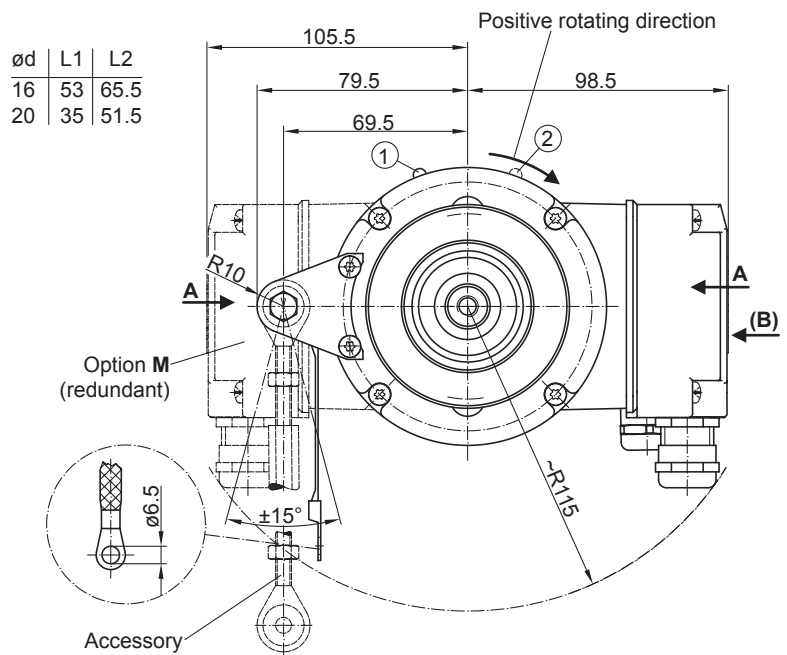
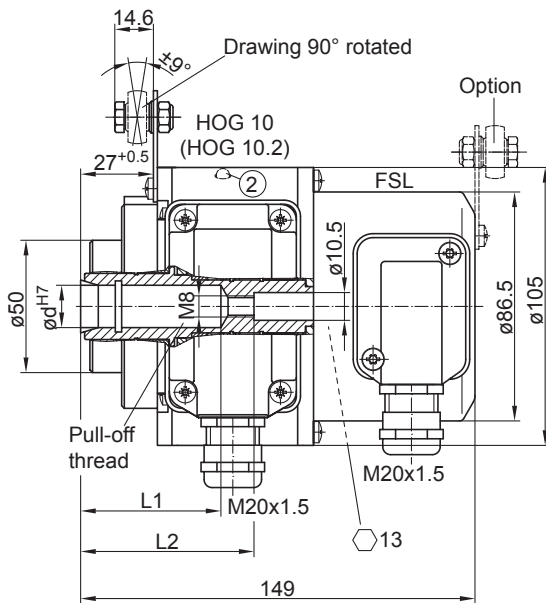

- ① Status LED (option EMS)
- ② Status LED (option **M** (redundant) and EMS)

Blind hollow shaft

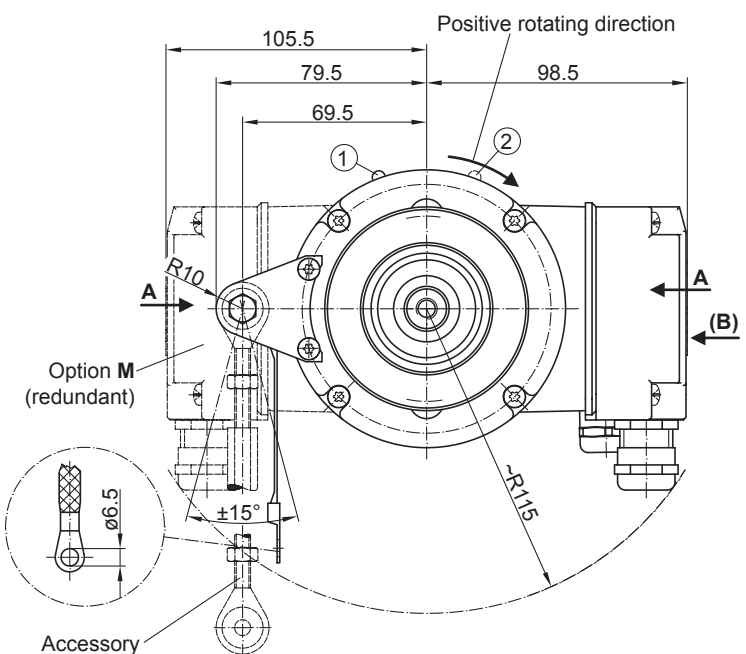
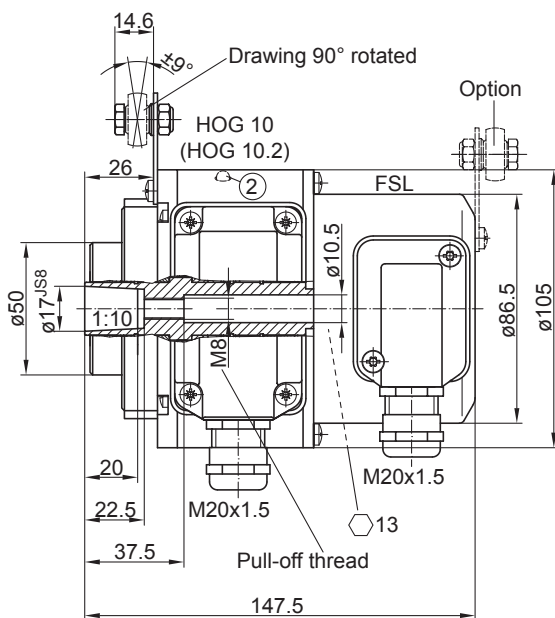

- ① Status LED (option EMS)
- ② Status LED (option **M** (redundant) and EMS)

Cone shaft