

# GCA5 - SAE J1939 up to 7.8 m

Interface SAE J1939

Measuring length absolute 6 m and 7.8 m

## Preliminary

### Overview

- Interface SAE J1939
- Redundant version
- Magnetic sensing method
- Operating temperature -40...+85 °C
- Protection IP 67
- Flange connector M12 or cable
- Measuring length 6 m and 7.8 m
- Designed for harsh environmental conditions
- Removable rubber plugs for drainage
- Load dump protection
- Integrated inclination sensor



### Technical data

#### Technical data - electrical ratings

Voltage supply	8...36 VDC
Reverse polarity protection	Yes
Short-circuit proof	Yes
Consumption typ.	30 mA (24 VDC, w/o load) 60 mA (24 VDC, w/o load, redundant)
Initializing time typ.	≤ 0.5 s after power on
Interface	SAE J1939
Function	Linear position feedback Angular position feedback
Measuring range	Up to 7.8 m (linear position) 0...360° (inclination angle)
Resolution	0.1 mm (linear position) 0.1° (inclination angle)
Temperature coefficient	0.04 °/K (inclination angle)
Linearity	±0.3 % (linear position) ±0.2° (inclination angle)
Absolute accuracy	±0.6 % FS (+25 °C / linear position) ±1.1 % FS (-40...+85 °C / linear position) ±0.3° (+25 °C / inclination angle)
Sensing method	Magnetic
Code sequence	Programmable
Load dump protection	ISO 16750-2 Test Level 4, 12 V/24 V systems
Interference immunity	EN 61000-6-2
Emitted interference	EN 61000-6-4
Programmable parameters	Operating modes Rotating direction Scaling Zero position

#### Technical data - mechanical design

Protection EN 60529	IP 67 (housing, drainage holes closed) IP 54 (cable inlet)
Material	Cable: stainless steel cable AISI 304 coated with nylon PA12 Housing: plastic
Operating temperature	-40...+85 °C
Service life	typ. 500.000 (depends on the type of load)
Measuring length	6 m 7.8 m
Cable acceleration	≤10 m/s <sup>2</sup>
Cable speed	≤1 m/s
Cable diameter	0.7 mm
Cable fastening	Eyelet Height: 5 mm Internal diameter: 8 mm Outer diameter: 15 mm
Pull-in force	>1.5 N (pull-in force reduced at low temperatures)
Pull-out force	≤8 N
Relative humidity	95 % non-condensing
Resistance	EN 60068-2-6 Vibration 10 g, 10-2000 Hz EN 60068-2-27 Shock 50 g, 11 ms
Weight approx.	625 g
Connection	Cable 2 m, radial Flange connector M12, 5-pin
Instruction	Please consider the assembly instructions

### Optional

- With integrated terminating resistor

Preliminary

**Installation position**

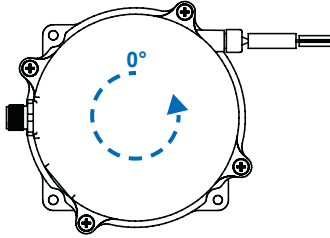

Position 1  
0/360°

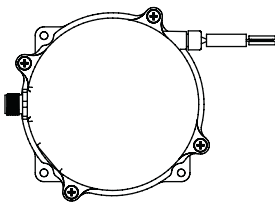

Position 2  
+90°

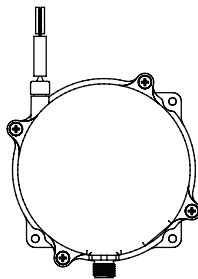

Position 3  
+180°

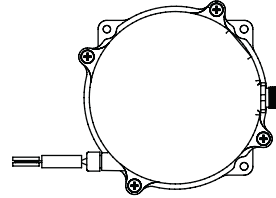

Position 4  
+270°

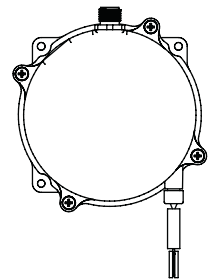

**Terminal assignment**

**Flange connector M12, male, 5-pin, A-coded**

Pin	Signals	Description
1	CAN_GND	Ground connection relating to CAN
2	+Vs	Voltage supply
3	GND	Ground connection relating to +Vs
4	CAN_H	CAN Bus Signal (dominant High)
5	CAN_L	CAN Bus Signal (dominant Low)

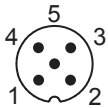

**Cable**

Core colour	Signals	Description
white	GND	Ground connection relating to +Vs
brown	+Vs	Voltage supply
green	CAN_H	CAN Bus Signal (dominant High)
yellow	CAN_L	CAN Bus Signal (dominant Low)
grey	CAN_GND	Ground connection relating to CAN

Cable data: 5 x 0.5 mm<sup>2</sup>, 2 m

Terminals GND and CAN\_GND are internally connected and identical in their functions.

# GCA5 - SAE J1939 up to 7.8 m

Interface SAE J1939

Measuring length absolute 6 m and 7.8 m

Preliminary

## SAE J1939 features

Programmable parameters	Rotating direction Scaling Zero position
Default	Baud rate 250 kbit/s Channel A: ECU address 4 (04h) Channel A: ECU address 5 (05h) Time-driven: 100 ms

## Data transfer

### ECU address 4

#### PGN65363 – cyclic message (PDU2 format)

LSB	...	...	MSB	...	...	...	...
Byte 0	1	2	3	4	5	6	7
linear position 0 → 60000\78000 <sub>dec</sub> in steps of 0.1 mm position increasing in size and value			Speed value		Status		

#### PGN65364 – cyclic message (PDU2 format)

LSB	...	...	MSB	...	...	...	...
Byte 0	1	2	3	4	5	6	7
inclination angle 0 → 3600 <sub>dec</sub> in steps of 0.1° angle increasing in size and value							

### ECU address 5

#### PGN65363 – cyclic message (PDU2 format)

LSB	...	...	MSB	...	...	...	...
Byte 0	1	2	3	4	5	6	7
linear position 0 → 60000\78000 <sub>dec</sub> in steps of 0.1 mm position increasing in size and value			Speed value		Status		

#### PGN65364 – cyclic message (PDU2 format)

LSB	...	...	MSB	...	...	...	...
Byte 0	1	2	3	4	5	6	7
inclination angle 0 → 3600 <sub>dec</sub> in steps of 0.1° angle increasing in size and value							

# GCA5 - SAE J1939 up to 7.8 m

Interface SAE J1939

Measuring length absolute 6 m and 7.8 m

Preliminary

## Dimensions

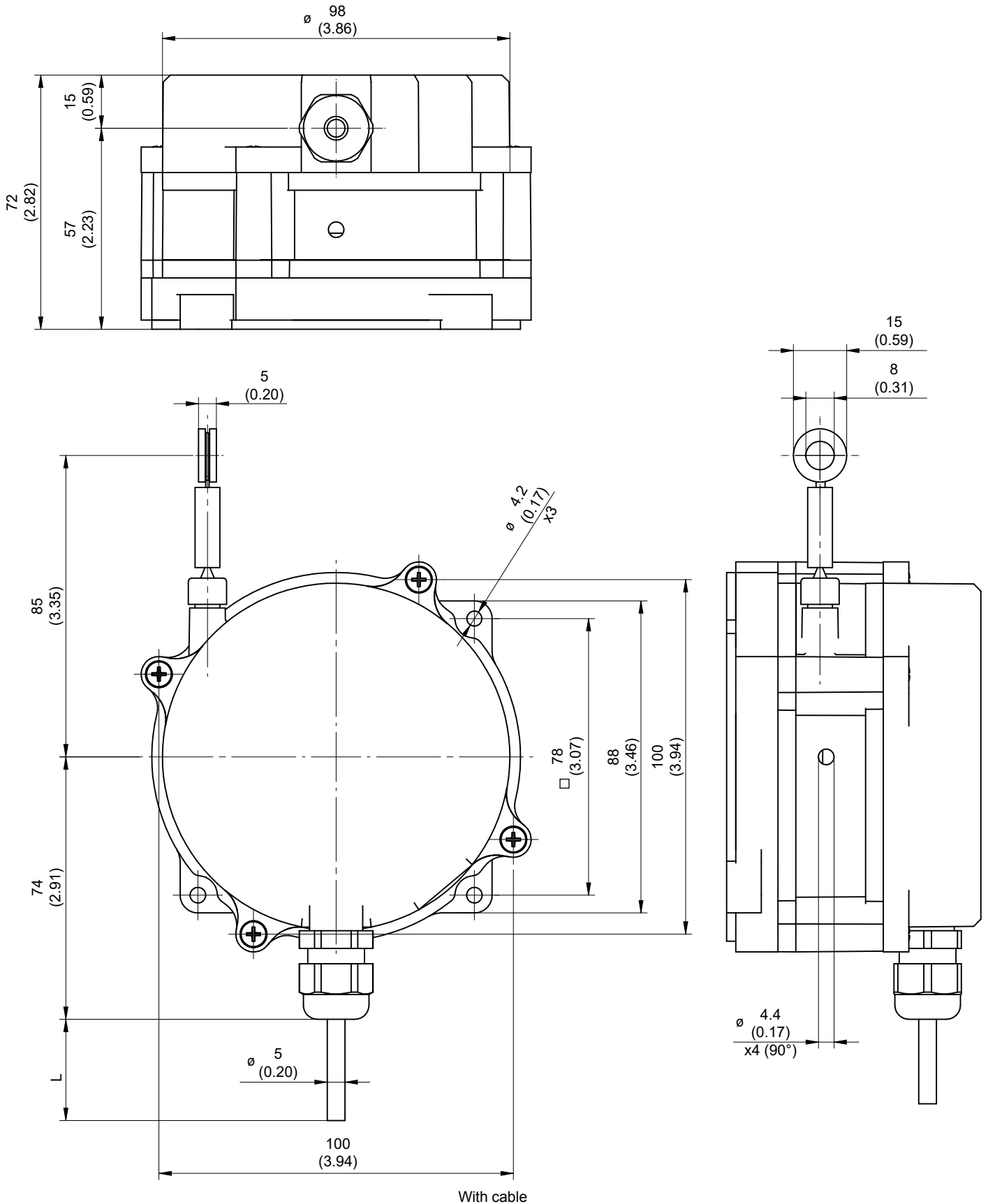

# GCA5 - SAE J1939 up to 7.8 m

Interface SAE J1939

Measuring length absolute 6 m and 7.8 m

Preliminary

## Dimensions

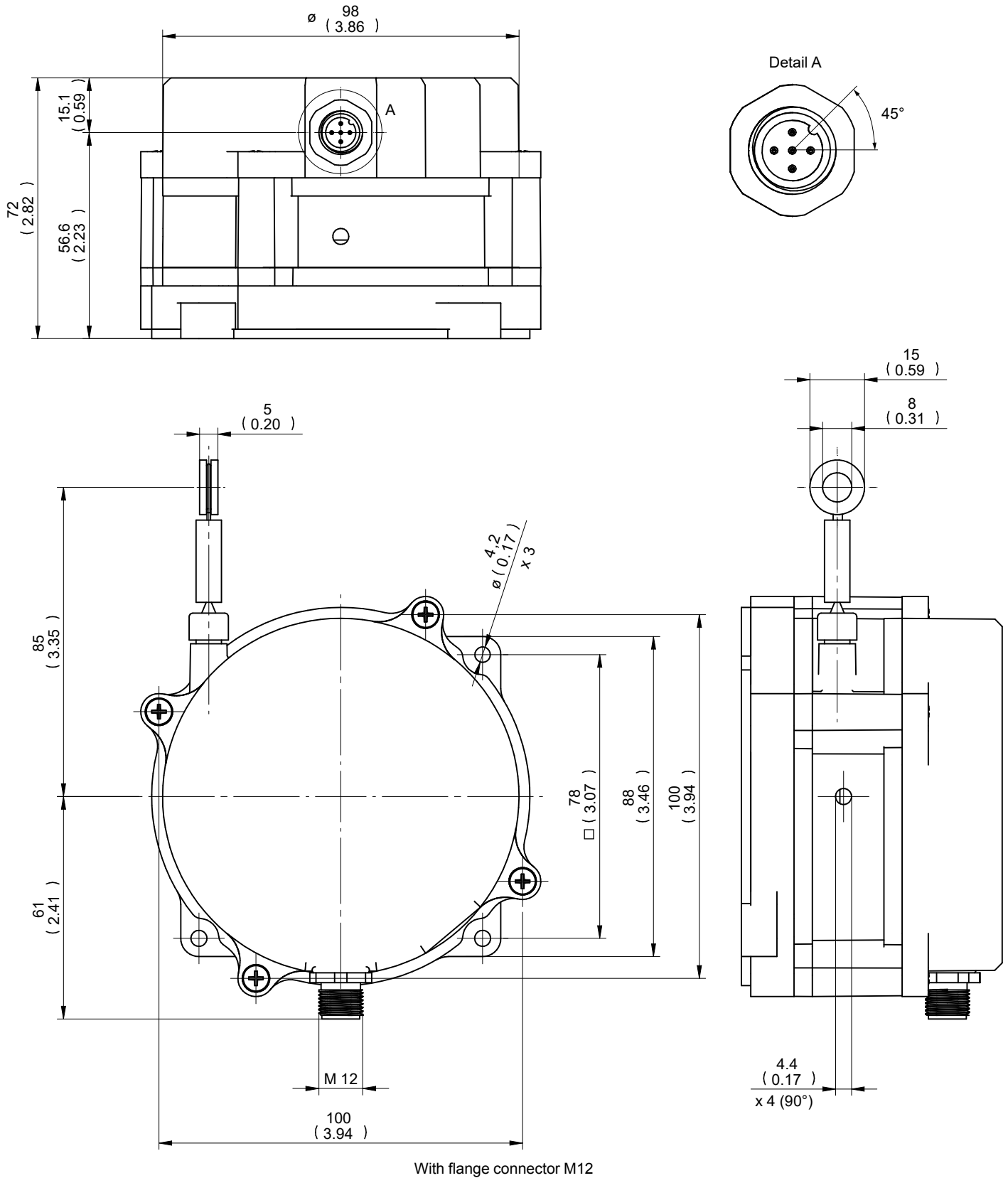

# GCA5 - SAE J1939 up to 7.8 m

Interface SAE J1939

Measuring length absolute 6 m and 7.8 m

Preliminary

**Ordering reference**

	GCA5	-	P	M	###	.	R	C	#	.	##	0	.	A	###	####
<b>Product</b>	GCA5															
<b>Type</b>	Plastic		P													
<b>Technology</b>	Magnetic			M												
<b>Measuring range</b>	6.0 m				060											
	7.8 m				078											
<b>Measuring wire fixation</b>	Ring						R									
<b>Measuring wire diameter</b>	0.70 mm							C								
<b>Connection</b>	Cable radial, 2 m															L
	Flange socket radial, M12, 5-pin, male contacts, CCW															N
<b>Voltage supply / output</b>	8...36 VDC, SAE J1939															CD
	8...36 VDC, SAE J1939 redundant (2-channel design)															CR
<b>Resolution supplement</b>	No option															0
<b>Operating temperature</b>	-40...+85 °C															A
<b>Option inclinometer</b>	1-dimensional / 0...360°															136
	No option															
<b>Option terminating resistor</b>	With integrated terminating resistor															4816
	No option															