

EB360R.MC-C.S012.AC6C1.14180N

Magnetic multiturn encoders, magnetic rotor for screw mounting

Article number: 11720912

Overview

- Non contact absolute encoder / CANopen®
- Parameterizable resolution up to 14 bit single- / 18 bit multiturn
- Precise magnetic sensing
- Reliable outdoor design
- High ingress protection IP 69K
- Corrosion protection CX (C5-M)
- High resistance to shock and vibrations
- Cable 1 m, open cable end
- Speed information mappable
- Magnetic rotor included in delivery (calibrated set)



Technical data

Technical data - electrical ratings

Voltage supply	10...30 VDC
Consumption typ.	20 mA (24 VDC, w/o load)
Initializing time	≤ 170 ms after power on
Interface	CANopen®
Function	Multiturn
Profile conformity	CANopen® CiA communication profile DS 301, LSS profile DSP 305, device profile DS 406
Steps per revolution	16384 / 14 bit
Number of revolutions	262144 / 18 bit
Output stages	CAN-Bus, LV (3.3 V) compatible ISO 11898
Absolute accuracy	±0.3 ° (+20 ±15 °C) ±0.5 ° (-40...+85 °C)
Sensing method	Magnetic
Code sequence	CW: ascending values with clockwise sense of rotation (looking at flange)
Interference immunity	EN 61000-6-2
Emitted interference	EN 61000-6-4
Approval	UL approval / E217823 CE

Technical data - mechanical design

Size (flange)	ø36 mm
Magnet rotor	ø12 mm, screw mount
Protection EN 60529	IP 69K (sensor housing)
Operating speed	≤6000 rpm
Working distance	0.1 ... 1.7 mm (axial) ≤ 1 mm (radial)
Material	Housing: PA10T / GF30 Cable sheath: PUR Magnet rotor: stainless steel
Corrosion protection	IEC 60068-2-52 Salt mist for ambient conditions CX (C5-M) according to ISO 12944-2
Operating temperature	-40...+85 °C (see general information)
Relative humidity	95 %
Resistance	EN 60068-2-6 Vibration 30 g, 10-2000 Hz EN 60068-2-27 Shock 500 g, 1 ms
Weight approx.	100 g
Connection	Cable, length 1 m, open cable end

Optional

- Gear function (on request)
- Terminal resistance (on request)

General information

Self-heating correlated to installation and ambient conditions as well as to electronics and supply voltage must be considered for precise thermal dimensioning. Operating the encoder close to the maximum limits requires measuring the real prevailing temperature at the encoder flange.

Terminal assignment

Cable	
Core colour	Signals
white	0 V
brown	+Vs
green	CAN_H
yellow	CAN_L
grey	CAN_GND (not galvanic isolated)
Cable data: 5 x 0.5 mm ²	

CANopen® features

Process data	Position value Speed (mappable) Encoder diagnostic
Operating modes	Time-driven (Event-Time) Synchronously triggered (Sync)
Node Monitoring	Heartbeat Node guarding
Programmable parameters	Operating modes Total resolution Scaling Electronic gear function
Diagnosis	Multiturn sensing Position error Temperature exceeding Speed exceeding
Default	250 kbit/s Node-ID 1

Angular misalignment

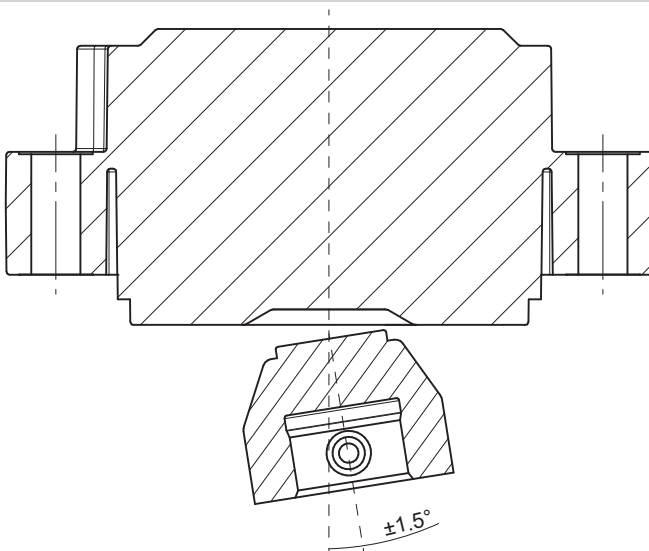

Working distance

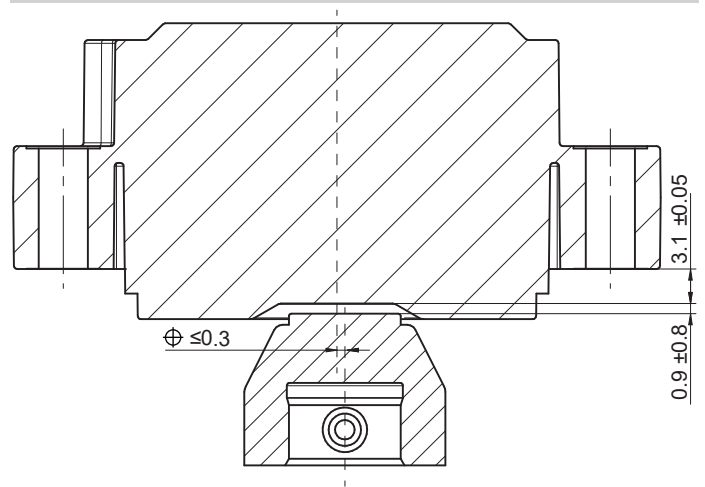

Working distance axial and radial eccentricity

The ideal working distance of the magnet related to the encoder is at an eccentricity of 0 mm and an axial distance of 0.9 mm. Deviation affects the accuracy as shown in following diagram.

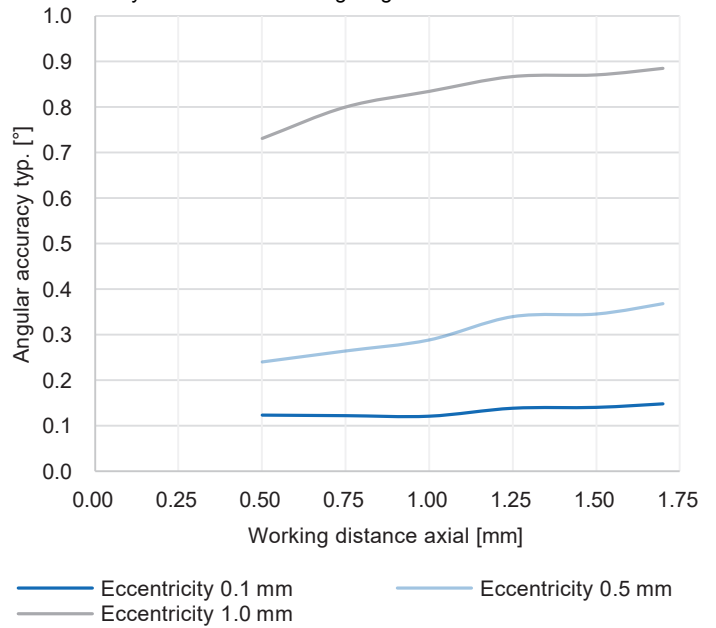

Mounting recommendation

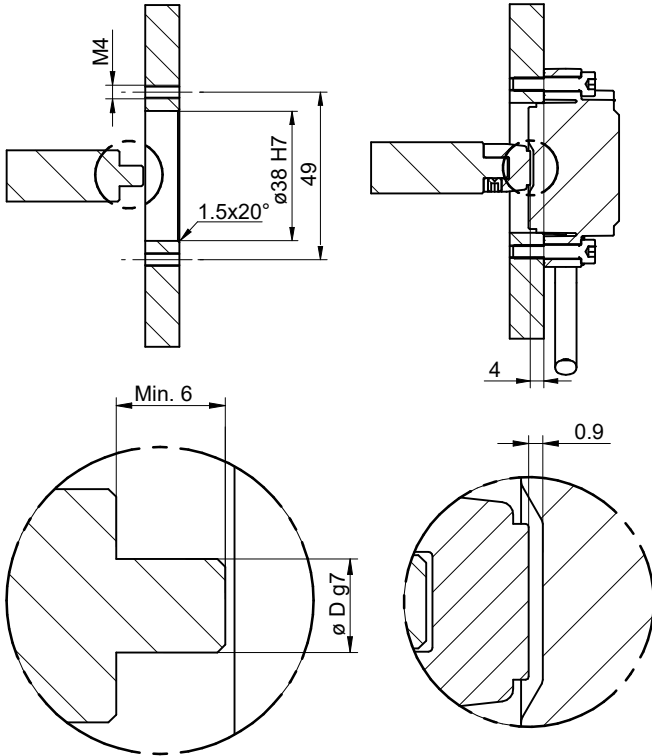

Screw mount