



Operating Manual

CH50I.M8
IO-Link Hub

EN-US

1 About this document

1.1 Purpose and scope of application

This document instructs the technical staff of the machine manufacturer or machine operator on the safe use of the described devices.

It does not include instructions on the safe use of the machine in which the devices are integrated. Information on this is found in the operating manual of the machine.

- Read this chapter carefully before you start working with the device.
- Study the documentation carefully before device commissioning.
- Store the manual in a place that is accessible to all users at all times for the entire service life of the device.



Understanding the present manual requires general knowledge about automation technology. In addition, planning and using automation systems requires technical knowledge which is not included in this manual.

1.2 Labels in this manual

Identifier	Usage	Example
<i>Dialog element</i>	Indicates dialog elements.	Click the OK button.
<i>Unique name</i>	Indicates the names of products, files, etc.	<i>Internet Explorer</i> is not supported in any version.
Code	Indicates entries.	Enter the following IP address: 192.168.0.250

1.3 Warnings in this manual

Warnings draw attention to potential personal injury or material damage. The warnings in this manual indicate different hazard levels:

Symbol	Warning term	Explanation
	DANGER	Indicates an imminent potential danger with high risk of death or serious personal injury if not being avoided.
	WARNING	Indicates potential danger with medium risk of death or (serious) personal injury if not being avoided.
	CAUTION	Indicates a danger with low risk, which could lead to light or medium injury if not avoided.
	NOTE	Indicates a warning of material damage.
	INFO	Indicates practical information and tips that enable optimal use of the devices.

1.4 Scope of delivery

Delivery includes:

- 1 x CH50I device
- 5 x product label
- General information sheet (11042373)

1.5 Trademarks

The present documentation uses the trademarks of the following companies and institutions:

IO-Link

c/o PROFIBUS User Organisation e.V. (PNO)

1.6 Specifications

Specification	Link
<i>IO-Link</i> Version 1.1.2 of 07.2013	www.io-link.com



INFO

The features of IO-Link specification V 1.1.3 are supported.

2 General information

Intended use

This product is a precision device and serves the detection of items, objects, or physical measurement variables and the preparation or provision of measured values as electric variables for the higher-level system.

Unless specifically labeled, this product may not be used in explosive environments.

Commissioning

Assembly, installation, and calibration of this product may only be performed by a specialist.

Installation

Only use the fasteners and fastener accessories intended for this product for installation. Outputs not in use must not be wired. Unused wires of cable outputs must be insulated. Do not go below the permissible cable bending radii. Disconnect the system from power before the product is electrically connected. Use shielded cables to prevent electro-magnetic interference. If the customer assembles plug connections on shielded cables, then EMC-version plug connections should be used and the cable shield must be connected to the plug housing across a large surface area.

Disposal (environmental protection)



Used electrical and electronic devices may not be disposed of in household waste. The product contains valuable raw materials that can be recycled. Therefore dispose of this product at the appropriate collection point. For additional information visit www.baumer.com.

3 Safety

3.1 General safety instructions



⚠ DANGER

High electrical voltage in the machine/system.

Death or severe injuries resulting from electric shock.

- a) While working on the machine/devices, comply with the five safety rules of electrical engineering.

Protection of persons and material assets

- According to DIN VDE 0105-100 - Operation of electrical systems - Part 100: General definitions

The 5 Safety Rules

Protect against *high electrical voltage*

1. Switch off the device.
2. Secure against unwanted switchon.
3. Ensure that each pole is not live respectively under voltage.
4. Grounding and short-circuiting.
5. Cover or block neighboring parts under voltage.

Qualified personnel

The appliance may only be installed, commissioned and operated by qualified personnel who have received safety training.



INFO

At all times, the instruction manual must be made available to the operator at the machine the device is operated at.



INFO

Any manipulation/modification of hardware and software only qualified *Baumer* personnel, except for firmware updates.

Intended use

The device has been designed and manufactured for:

- Industrial use.
- Operation within the specified ambient conditions.
- Use in the field.



INFO

Radio interference may occur if the device is used in domestic or mixed-use areas.

- a) Observe the applicable standards for residential or mixed-use areas!

Predictive misuse

The device:

- must not be modified in design, technology or electrics.
- must only be deployed in the applications described in the present instruction manual and the related data sheets.
- must not be deployed as a safety-related device. It does not comply with the relevant standards. Any safety functions in the system are not ensured.
- only use the device in environments with corresponding IP-rating.
- only clean the device with oil-free compressed air and a leather cloth.
- do not use the device as a climbing aid.

4 Description

4.1 Device

IO-Link hub (*CH50I.M8*)

- IO-Link hub in 30 mm plastic housing
- 1 x M12 IO-Link Class A
- 8 x M8 I/O
- 8 configurable digital inputs/outputs



4.2 Product name nomenclature

The nomenclature is based on a scheme indicating the product functionality.

CH50I	Product family
M8	Slot size

4.3 Device structure

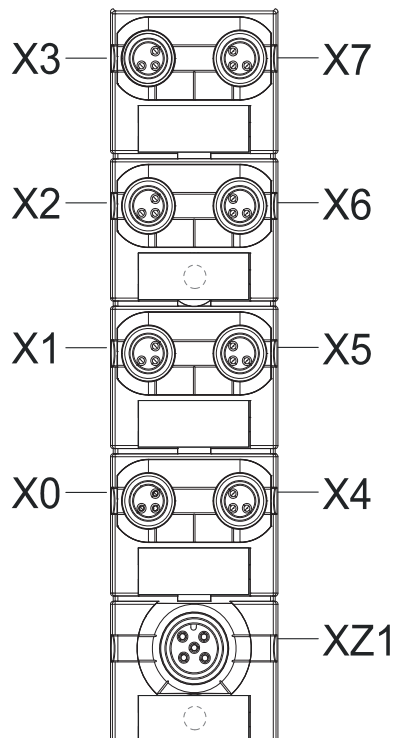

- X0 ... X7** Digital inputs and outputs US
- XZ1** Module supply, IO-Link Class A

4.4 Pin assignment

IO-Link Class A

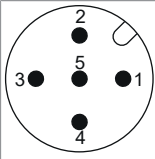
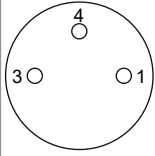
IO-Link	XZ1 (M12 connector)	
	Pin 1	24 V US (L+)
	Pin 2	n.c.
	Pin 3	0 V US (L-)
	Pin 4	C/Q IO-Link
	Pin 5	n.c.
DIO	X0 ... X7 (mating M8)	
	Pin 1	24 V US (L+)
	Pin 3	0 V US
	Pin 4	DIO US

5 Technical data

5.1 Electrical Data

Supply		
Operating voltage US		24 V DC
Voltage range US		18 ... 30 V DC
Total current US	≤50 °C (see Derating)	≤4 A
Current consumption	At idle	≤40 mA
Galvanic isolation		No

Total current US

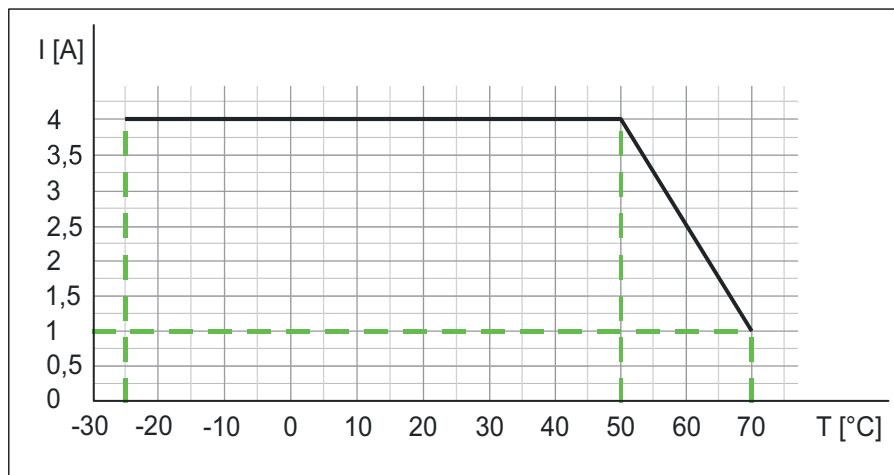

/// 1: Total current US

IO-Link		
Communication rate		COM3
Transmission rate		230.400 Bit/s
Bus protocol		IO-Link V1.1.2 compatible with IO-Link V1.1.3
IO-Link cycle time		≥1 ms
VendorID		0x015E
DeviceID		0x018A9F
Process data		4 bytes (inputs), 2 bytes (outputs)

Sensor supply +		
Terminal/mating		M8
Operating voltage		24 V DC
Power supply	Per pair of ports (X0+X1, X2+X3, X4+X5, X6+X7)	≤1 A

Input (DI)		
Terminal/mating		M8
Conductor cross-section		≤0.75 mm ²
Cable length		≤30 m
Input characteristic	EN 61131-2	Type 1 + Type 3
Input filter		1 to 10 ms, adjustable
Output (DO)		
Terminal/mating		M8
Conductor cross-section		≤0.75 mm ²
Cable length		≤30 m
Output current	Per pin	≤0.5 A
Switching frequency	Ohmic load	≤25 Hz

5.2 Ambient conditions

Climate		
Operating temperature		-25 °C ... +70 °C
Storage temperature		-40 °C ... +85 °C
Installation height	Above sea level	≤3000 m
Relative humidity		≤95 %
Mechanical		
Oscillation test	EN 60068 Part 2-6	5 ... 500 Hz; constant amplitude 1 mm; acceleration 15 g
Shock test	EN 60068 Part 2-27	50 g, duration 11 ms
Electrical safety		
Protection	IP protection rating is not considered in UL approval	IP68
Protection rating		III
Level of contamination		2
EMC emission		
Radiated interference E-field	EN 61000-6-4 Emission	QP: 40 dB _μ V/m @ 30 ... 230 MHz QP: 47 dB _μ V/m @ 230 ... 1000 MHz
EMC-immunity		
Discharge of static electricity (housing)	EN 61000-4-2	±4 kV @ contact ±8 kV @ air
Electromagnetic HF fields (housing)	EN 61000-4-3 RF-Field	10 V/m

EMC-immunity		
Fast transient electrical disturbance variables (burst) DC inputs/outputs	EN 61000-4-4	±2 kV I/O supply ±1 kV data line/ ±1 kV I/O line
Magnetic field	EN 61000-4-8	30 A/m @ 50 Hz
Variables of conducted disturbance, HF fields	EN 61000-4-6, irregular	10 V

5.3 Protection

Device protection		
Overvoltage protection		Yes
Overload protection device supply	To be ensured by load circuit monitoring	Yes
Inverse-polarity protection device supply		Yes
Short-circuit protection sensor supply		Electronically
Short-circuit protection output		Electronically
Protective circuit input	Internal	Suppressor diode

5.4 Product reliability

Product reliability		
MTTF	SN 29500 (at 40 °C and rated data)	57 years

5.5 Product reliability

Product reliability		
MTTF	SN 29500 (at 40 °C and rated data)	94 years

5.6 Mechanical data

Mounting data		
Weight	Net	129 g
Dimensions	L x W x H	126 x 30 x 34.5 mm

5.7 Conformity, Approvals

Conformity, Approvals		
Product standard	EN 61131-2 Programmable Logic Controllers Part 2	Compliant
CE	2014/30/EU 2011/65/EU	Compliant
UKCA		Compliant
EMC	2014/30/EU	Compliant
REACH	No. 1907/2006	SVHC List
WEEE	2012/19/EU	Compliant
ULus		E201820
RoHS	2011/65/EU & 2015/863	Exception 6c&7a
China RoHS	SJ/T 11364-2014	25 EPUP

Hazardous substance (有害物質)							
	Part Name	Lead	Mercury	Cadmium	Hexavalent	Polybrominated	Polybrominated
	零件名稱	(Pb) 鉛	(Hg) 汞	(Cd) 鎘	Chromium (Cr (VI)) 六价铬	biphenyls (PBB) 多溴联苯	diphenyl ethers (PBDE) 多溴联苯醚
	Component part PCB 组件部分 印刷电路板	X	O	O	O	O	O
	Connection Terminal/ Screws 接线端子 / 拧	X	O	O	O	O	O
<p>O: Indicates that the content of the harmful substance in all homogeneous materials of the component part is below the limit defined in GB/T 26572. O: 表明該有害物質在組成部分的所有均質材料的含量低於按GB/ T26572定義的限制。</p> <p>X: Indicates that the content of the harmful substance in at least one homogeneous material of the component part exceeds the limit defined in GB/T 26572. X: 表示該有害物質在組成部分中的至少一個均質材料的含量超過按GB / T26572定義的限制。</p>							

6 Installation

6.1 Requirements

Installation requirements:

- Even mounting surface to avoid mechanical tension.
- Provide proper grounding.
- Suitable installation site in terms of vibration and shock load, temperature and humidity (see [Technical data](#) ▶ 9j).
- Protected to prevent connection cables from being torn off accidentally.

Observe the following installation requirements:

- Installation in the immediate vicinity of sensor/actuator
- Even mounting surface to avoid mechanical tension
- Earthed mounting surface for ring terminal earthing
- Short cable distance to all components
- Sufficient space to ease replacement and plug-in connections
- Appropriate installation site in terms of vibration and shock, temperature and humidity (see chapter Technical Specifications)
- Protected site to prevent connection cables from being torn off accidentally
- Diagnostic LEDs visible during operation

6.2 Dimensions

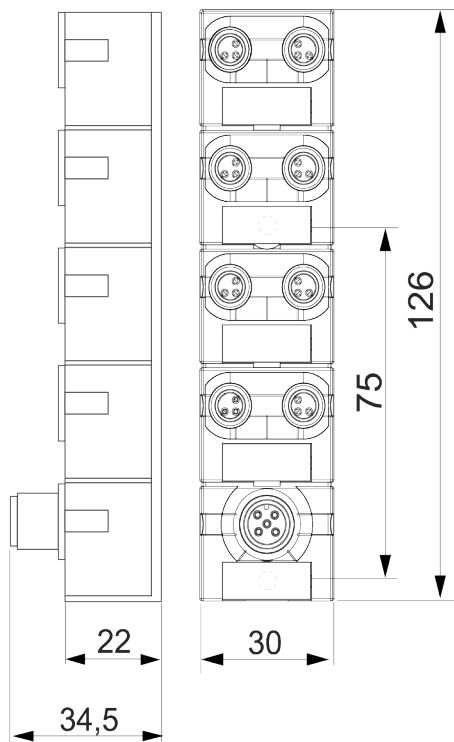

6.3 Mounting distance

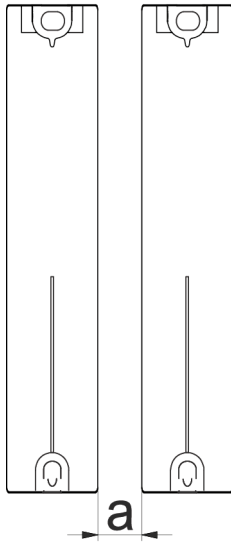

III. 2: Distance in mm

- a | Straight connector: 5 mm
 Angled connector: 50 mm



INFO

Minimum distance of 50 mm required where using angled connectors.

6.4 Functional ground

For EMC compliance, a ring cable lug is required.
 Input and output shield connection of is via the ring cable lug.

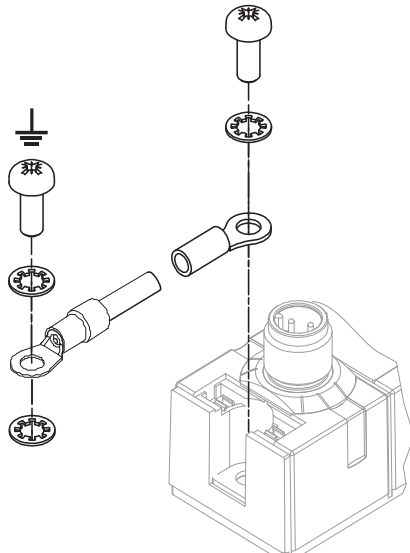

III. 3: Fastening the ring cable lug

Also see about this

[Accessories \[▶ 32\]](#)

6.5 Mounting the device



WARNING

Material damage due to incorrect installation.

Use fastening screws that are appropriate for the mounting surface.

- a) Make sure the fastening screws are appropriate for use with the intended mounting surface.
- b) Tighten the screws carefully. Observe the specified tightening torques.



WARNING

Material damage through improper use.

Do not use the devices as climbing aids. Devices may come off by improper use or might be damaged.

- a) Install the device in a way that it cannot be abused as climbing aid.

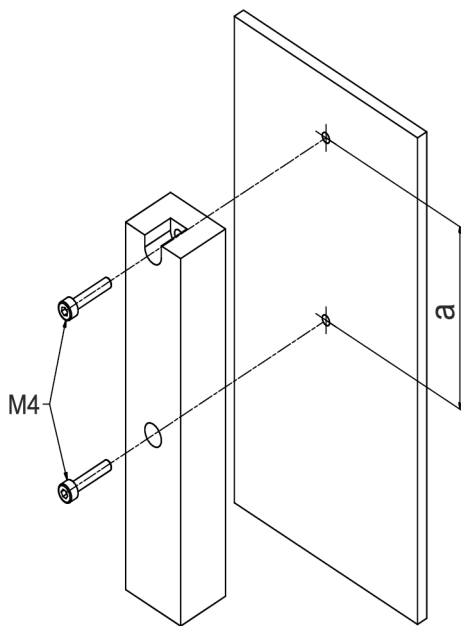

III. 4: Mounting with two screws M4

a = 75 mm

When mounting the device, observe the order indicated below:

Instruction:

- a) Align the housing.
- b) Use a conductive screw to fasten the ring cable lug.
- c) Slightly tighten the first M4 screw.
- d) Slightly tighten the second M4 screw.
- e) Tighten both M4 screws to the specified torque.

Also see about this

[Functional ground \[▶ 14\]](#)

7 Installation

7.1 Electrical installation of the device

DANGER

High electrical voltage in the machine/system.

Death or severe injuries resulting from electric shock.

- a) Device connection must be performed by qualified personnel only.
- b) While working on the machine/devices, comply with the five safety rules of electrical engineering.

Protective measures for connection

- Compliant to *IEC 60364 - Protection against electric shock..*



CAUTION

Hot surface.

Minor personal injuries and damage to the device when contacting hot surfaces.

- a) Wear suitable isolating gloves.
- b) Only use connection cables that meet thermal requirements.

7.1.1 Connection lines

WARNING

Risk of fire due to short circuit.

Supply lines and/or devices may short circuit when damaged causing overheating and fire.

- a) Provide intelligent current monitoring or fuse.



INFO

Maximum length of sensor and actuator cables is limited to 30 m.

7.2 Ensuring Tightness (IP67)

CAUTION



Leaky housing.

Risk of personal injury and material damage due to failure caused by ingress of conductive liquids.

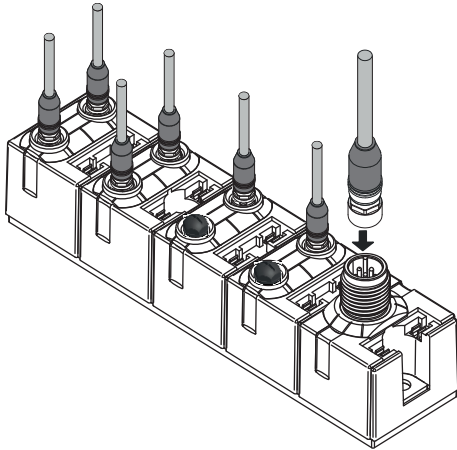
- a) Seal any male and female connectors not in use.



III. 5: Cable connection

M8	0.4 Nm		CAM8.WS9-11238649
M12	0.6 Nm		CAM12-W13-11238690



INFO

A large selection of connection cables can be found on the Baumer website <https://www.baumer.com>.

8 Operation

NOTICE

After writing the *Application Specific Tag* to the IO-Link hub, the hub would briefly interrupt IO-Link connection if the text is not identical to that stored in the hub.

8.1 LED indicator

The devices feature the following separate LED indicators:

- LED indicator for IO-Link and sensor supply US
- LED indicator for inputs/outputs





Either indicated by continuous or flashing LEDs.

8.1.1 LED indicator US and IO-Link

The device features a two-color LED for indicating IO-Link status and sensor supply status US. IO-Link status is indicated by the LED on green, the US status by the LED on red.





A mixture of flashing green and red may result in flashing amber in the event of overlapping.

Two-color LED indicator IO-Link and US

Indicator	Status	Description
 Green	On continuous	IO-Link not in status <i>OPERATE</i> , no cyclical data communication present; sensor supply OK
 Green	Flashing at 1 Hz	IO-Link in status <i>OPERATE</i> , cyclical data communication; sensor supply OK
 Red	On continuous	Short circuit DO, temperature warning etc.
 Red	Flashing at 1 Hz	IO-Link communication error
 Off	Off	Device off, no IO-Link connection present

Tab. 1: Indicator IO-Link and US

Firmware update

Indicator	Status	Description
 Green	On continuous	IO-Link in status <i>IDLE</i> Firmware update successfully executed
 Green	Flashing at 1 Hz	IO-Link in status <i>PREOPERATE</i> / <i>OPERATE</i> Update is not yet being executed
 Red	On continuous	Update failed
 Green/red	Flashing at 2 Hz	IO-Link in status <i>PREOPERATE</i> / <i>OPERATE</i> Update is being executed
 Off	Off	Device off, no IO-Link connection present



Tab. 2: Firmware update

NOTICE

Error-free operation no longer guaranteed at US <18 V.

8.1.2

LED indicator for inputs and outputs

Indicator	Status	Input voltage	Description	Logo value
 Yellow	On continuous	24 V	channel at	1
 Red	On continuous	0 V	Short circuit or overload DO	0
 Off	Off	0 V	Device off or firmware update being executed	0

Tab. 3: LED indicator digital inputs/outputs

Error at input or output

In the event of error (short circuit, overload or power recovery) present at minimum one input or output, the LEDs of all input and output slots light up red.

8.2 IO-Link object directory

8.2.1 DPP (Direct Parameter Page)

ISDU index	DPP index	Object name	Access	Length in bytes	Meaning / Default value
Identification					
0x0000	0x00	MasterCommand	W	1	
	0x01	MasterCycleTime	R/W	1	
	0x02	MinCycleTime	R	1	
	0x03	M-sequenceCapability	R	1	
	0x04	RevisionID	R/W	1	
	0x05	ProcessDataIn	R	1	
	0x06	ProcessDataOut	R	1	
	0x07	VendorID 1 (MSB)	R	1	0x015E
	0x08	VendorID 2 (MSB)	R	1	
	0x09	DeviceID 1 (Octet 2, MSB)	R/W	1	0x01
	0x0A	DeviceID 1 (Octet 1, MSB)		1	0x8A
	0x0B	DeviceID 1 (Octet 0, LSB)		1	0x018A9F
	0x0C	FunctionID 1 (MSB)	R	1	
	0x0D	FunctionID 2 (MSB)		1	
	0x0E	Reserved	R	1	
0x0F	SystemCommand	W	1		
0x0002		SystemCommand	R	1	
0x0003		DataStorageIndex	R	variable	
0x000D		ProfileCharacteristic	R	variable	
0x000E		PDInputDescriptor	R	variable	
0x000F		PDOOutputDescriptor	R	variable	
0x0010		VendorName	R	64	Baumer
0x0011		VendorText	R	64	www.baumer.com
0x0012		ProductName	R	64	CH50I.M8
0x0013		ProductID	R	64	11261575
0x0014		ProductText	R	64	Digital Hub DIO 8 M8
0x0015		SerialNumber	R	16	Consecutive serial number, set by default
0x0016		HardwareRevision	R	64	e.g. "01.00"
0x0017		FirmwareRevision	R	64	e.g. "V.1.00.00"
0x0018		ApplicationSpecific-Tag	R	16 ... 32	User-specific name, e.g. "System 3 / Port 4"
0x0019		FunctionTag	R	32	
0x001A		LocationTag	R	32	

ISDU index	DPP index	Object name	Access	Length in bytes	Meaning / Default value
Identification					
0x0020		Error Count	R	2	
0x0024		DeviceStatus	R	1	<ul style="list-style-type: none"> ■ 0: Device is operating properly ■ 1: Maintenance Required ■ 2: Out of Specification ■ 3: Functional Check ■ 4: Failure ■ 5 ... 255: Reserved
0x0025		DetailedDeviceStatus	R	variable	6 x (Octet 1: EventQualifier, Octet 2, 3: EventCode)
0x0028		ProcessDataInput	R	PD length	
0x0029		ProcessDataOutput	R	PD length	
0x0031 ... 0x003F		Reserved for profiles			

8.2.2 ISDU (Indexed Service Data Unit)

ISDU index	Object name	Access	Length in bytes	Significance	Default value
0x0040	Status: Power Supply Status US	R	1	Output of US status: <ul style="list-style-type: none"> ■ 0x00 = OK ■ 0x01 = undervoltage ■ 0x02 = overvoltage 	–
0x0041	Status: Power Supply Value US	R	1	Output of measured US voltage in increments of 0.1 V. Updated every 10 ms.	–
0x0042	Status: Power Supply Status UA	R	1	Outputs UA status: <ul style="list-style-type: none"> ■ 0x00 = OK ■ 0x01 = undervoltage ■ 0x02 = overvoltage ■ 0x03 = OFF / not connected 	–
0x0050	Diagnosis: Short Circuit Detection DO	R	16	Allows you to read a short circuit being present at a specific channel. <ul style="list-style-type: none"> ■ Sub-index 1: X0 pin 4 ■ Sub-index 2: X1 pin 4 ■ ... ■ Sub-index 7: X6 pin 4 ■ Sub-index 8: X7 pin 4 	–

ISDU index	Object name	Access	Length in bytes	Significance	Default value
0x0060	Identification: Identification ID	R/W	2	Number for module identification. Value is provided in the input process data.	0x0000
0x0061	Identification: User Defined Serial Number	R/W	2	User-defined serial number. It may be used to ensure that the device will only be connected to an appropriate master.	0x0000
0x0062	Diagnosis: Disable General Diagnosis	R/W	16	Adjustable diagnostics: <ul style="list-style-type: none"> ■ 0 = enabled ■ 1 = disabled ■ Sub-index 1: IO-Link event code transmitted to master ■ Sub-index 2: US - diagnosed undervoltage ■ Sub-index 3: US - diagnosed overvoltage ■ Sub-index 4: US - LED status ■ Sub-index 5: UA - Diagnosis "Not connected" ■ Sub-index 6: UA - diagnosed undervoltage ■ Sub-index 7: UA - diagnosed overvoltage ■ Sub-index 8: UA - LED status ■ Sub-index 9: TEMP - diagnosed low temperature ■ Sub-index 10: TEMP - diagnosed high temperature ■ Sub-index 11: TEMP - LED status ■ Sub-index 12 ... 16: Reserved 	0
0x0063	Module: L+ Current Limit	R/W	1	US (L+) current limited to 200 mA when operated at IO-Link master port that does not supply sufficient current for unrestricted IO-Link hub operation. <ul style="list-style-type: none"> ■ 0 = No US (L+) current limitation ■ 1 = US (L+) current limitation enabled at 200 mA 	0

ISDU index	Object name	Access	Length in bytes	Significance	Default value
0x0070	In-/Outputs: Bitmap- ping Layout	R/W	1	Bit mapping layout of process data. <ul style="list-style-type: none"> 0 = port-based bit mapping 1 = pin-based bit mapping 	0
0x0072	In-/Outputs: Channel Configuration	R/W	16	Setting the I/O function per channel. <ul style="list-style-type: none"> Sub-index 1: X0 pin 4 Sub-index 2: X1 pin 4 ... Sub-index 7: X6 pin 4 Sub-index 8: X7 pin 4 Setting per channel (sub-index): <ul style="list-style-type: none"> 0 = Auto configuration / universal (DIO) 1 = Input 2 = Output 	0
0x0080	Inputs: Inverting Input Logic	R/W	1	Input logic inversion per channel. <ul style="list-style-type: none"> Bit 0: X0 pin 4 Bit 1: X1 pin 4 ... Bit 6: X6 pin 4 Bit 7: X7 pin 4 Setting per channel (sub-index): <ul style="list-style-type: none"> 0 = standard, not inverted 1 = Inverted 	0
0x0081	Inputs: Signal Extension / Impulse Stretching	R/W	16	Input pulses prolonged in steps of 10 ms. <ul style="list-style-type: none"> Sub-index 1: X0 pin 4 Sub-index 2: X1 pin 4 ... Sub-index 7: X6 pin 4 Sub-index 8: X7 pin 4 Setting per channel (sub-index): <ul style="list-style-type: none"> 0 = 0 ms / OFF 1 = 10 ms 2 = 20 ms 3 = 30 ms 	0

ISDU index	Object name	Access	Length in bytes	Significance	Default value
				<ul style="list-style-type: none"> ▪ ... ▪ 255 = Reserved 	
0x0082	Inputs: Input De-bounce / Filter Time	R/W	1	<p>Setting the input filter time per channel.</p> <ul style="list-style-type: none"> ▪ Sub-index 1: X0 pin 4 ▪ Sub-index 2: X1 pin 4 ▪ ... ▪ Sub-index 7: X6 pin 4 ▪ Sub-index 8: X7 pin 4 <p>Setting per channel (sub-index):</p> <ul style="list-style-type: none"> ▪ 0 = OFF (no filtering) ▪ 1 = 1 μs ▪ 2 = 10 μs ▪ 3 = 100 μs ▪ 4 = 1 ms ▪ 5 = 2 ms ▪ 6 = 3 ms ▪ 7 = 5 ms ▪ 8 = 10 ms 	4
0x0090	Outputs: Short Circuit Recovery Behavior	R/W	16	<p>Defines the behavior of each output (channel) after short circuit / overload:</p> <ul style="list-style-type: none"> ▪ Bit 0: X0 pin 4 ▪ Bit 1: X1 pin 4 ▪ ... ▪ Bit 6: X6 pin 4 ▪ Bit 7: X7 pin 4 <p>Setting per channel (sub-index):</p> <ul style="list-style-type: none"> ▪ 0 = Automatic reset after 60 sec. ▪ 1 = Manual reset via output process data <p>For manual reset, change the related process data bit from 0 to 1.</p>	0
0x0091	Outputs: Fail-Safe Behavior	R/W	16	<p>Defines the behavior of each output (channel) in the event of communication loss with master.</p> <ul style="list-style-type: none"> ▪ Sub-index 1: X0 pin 4 	0

ISDU index	Object name	Access	Length in bytes	Significance	Default value
				<ul style="list-style-type: none"> ■ Sub-index 2: X1 pin 4 ■ ... ■ Sub-index 7: X6 pin 4 ■ Sub-index 8: X7 pin 4 Setting per channel (sub-index): <ul style="list-style-type: none"> ■ 0 = logical 0 / OFF ■ 1 = logical 1 / ON ■ 2 = Hold last state 	

8.3 Diagnostic tools

8.3.1 Vendor-specific IO-Link events

NOTICE

In addition to the vendor-specific IO-Link events listed here, the standard events of the IO-Link specification are applicable as well.

Event code	Event type	Description
0x4000	Error	Temperature error
0x4210	Warning	Permitted device temperature exceeded
0x4220	Warning	Temperature below permitted device temperature
0xFF91	Notification	Data Storage (DS) upload by master required
0x5100	Error	General supply voltage error (UL1)
0x5110	Warning	Main supply overvoltage (UL1)
0x5111	Warning	Main supply undervoltage (UL1)
0x1830	Warning	Main supply overvoltage (UL2)
0x1831	Warning	Main supply undervoltage (UL2)
0x1832	Error	Secondary voltage error (UL2)
0x7710	Error	Short circuit
0x8CA0	Error	Overload/short circuit at DIO pin - port 0 pin 4
0x8CA1	Error	Overload/short circuit at DIO pin - port 0 pin 2
0x8CA2	Error	Overload/short circuit at DIO pin - port 1 pin 4
0x8CA3	Error	Overload/short circuit at DIO pin - port 1 pin 2
0x8CA4	Error	Overload/short circuit at DIO pin - port 2 pin 4
0x8CA5	Error	Overload/short circuit at DIO pin - port 2 pin 2
0x8CA6	Error	Overload/short circuit at DIO pin - port 3 pin 4
0x8CA7	Error	Overload/short circuit at DIO pin - port 3 pin 2
0x8CA8	Error	Overload/short circuit at DIO pin - port 4 pin 4
0x8CA9	Error	Overload/short circuit at DIO pin - port 4 pin 2
0x8CAA	Error	Overload/short circuit at DIO pin - port 5 pin 4
0x8CAB	Error	Overload/short circuit at DIO pin - port 5 pin 2

Event code	Event type	Description
0x8CAC	Error	Overload/short circuit at DIO pin - port 6 pin 4
0x8CAD	Error	Overload/short circuit at DIO pin - port 6 pin 2
0x8CAE	Error	Overload/short circuit at DIO pin - port 7 Pin 4
0x8CAF	Error	Overload/short circuit at DIO pin - port 7 pin 2
0x8CD0	Error	Overload/short circuit in sensor supply at Port 0 Pin 1
0x8CD1	Error	Overload/short circuit in sensor supply at Port 1 Pin 1
0x8CD2	Error	Overload/short circuit in sensor supply at Port 2 Pin 1
0x8CD3	Error	Overload/short circuit in sensor supply at Port 3 Pin 1
0x8CD4	Error	Overload/short circuit in sensor supply at Port 4 Pin 1
0x8CD5	Error	Overload/short circuit in sensor supply at Port 5 Pin 1
0x8CD6	Error	Overload/short circuit in sensor supply at Port 6 Pin 1
0x8CD7	Error	Overload/short circuit in sensor supply at Port 7 Pin 1

Tab. 4: IO-Link events

8.4

Process data

8.4.1

Port-based mapping

Process data digital inputs

Byte 0 Inputs X0 ... X3	
Bit	Contact
0	Pin4_X0
1	Reserved
2	Pin4_X1
3	Reserved
4	Pin4_X2
5	Reserved
6	Pin4_X3
7	Reserved

Byte 1 Inputs X4 ... X7	
Bit	Contact
0	Pin4_X4
1	Reserved
2	Pin4_X5
3	Reserved
4	Pin4_X6
5	Reserved
6	Pin4_X7
7	Reserved

NOTICE

Bytes 2 and 3 only supported by E0 devices.

Byte 2 Diagnostics	
Bit	Description
0	Error/Warning at power supply (too low or high)
1	Error/Warning because of temperature rating (threshold can be defined inside object)
2	Error/Warning at Input/Output (short-circuit or overload)
3	DIA at channel X 0 = channel 1 ... 15 = channel 16
4	DIA at channel X 0 = channel 1 ... 15 = channel 16
5	DIA at channel X 0 = channel 1 ... 15 = channel 16
6	DIA at channel X 0 = channel 1 ... 15 = channel 16
7	Global status 0 = no diagnostic 1 = fault detected

Byte 3 Module identification	
Bit	Description
0 ... 7	User defined module identification bits, e. g. for tool change applications; 0 = not used 1 ... 255 = ID value is read out from object

Process data Digital outputs

Byte 0 Inputs X0 ... X3	
Bit	Contact
0	Pin4_X0
1	Reserved
2	Pin4_X1
3	Reserved
4	Pin4_X2
5	Reserved
6	Pin4_X3
7	Reserved

Byte 1 Inputs X4 ... X7	
Bit	Contact
0	Pin4_X4
1	Reserved
2	Pin4_X5
3	Reserved
4	Pin4_X6
5	Reserved
6	Pin4_X7
7	Reserved

8.4.2 Pin-based mapping

Process data digital inputs

Byte 0 Inputs X0 ... X7	
Bit	Contact
0	Pin4_X0
1	Pin4_X1
2	Pin4_X2
3	Pin4_X3
4	Pin4_X4
5	Pin4_X5
6	Pin4_X6
7	Pin4_X7

Byte 1 Inputs X0 ... X7	
Bit	Contact
0 ... 7	Reserved

NOTICE

Bytes 2 and 3 only supported by E0 devices.

Byte 2	
Bit	Diagnostic tools
7	Global status 0 = No diagnosis 1 = Error
6	Channel X 0 = Channel 1 ... 15 = Channel 16

Byte 2	
Bit	Diagnostic tools
5	Channel X 0 = Channel 1 ... 15 = Channel 16
4	Channel X 0 = Channel 1 ... 15 = Channel 16
3	Channel X 0 = Channel 1 ... 15 = Channel 16
2	Input/output error or warning (short circuit or overload)
1	Device temperature too high or too low
0	Supply error or warning (overvoltage or undervoltage)

Byte 3 Device identification	
Bit	Description
0 ... 7	User-defined bits, e.g. for tool change 0 = not used 1 ... 255 = ID value read from object

Process data Digital outputs

Byte 0 Inputs X0 ... X3	
Bit	Contact
0	Pin4_X0
1	Reserved
2	Pin4_X1
3	Reserved
4	Pin4_X2
5	Reserved
6	Pin4_X3
7	Reserved

Byte 1 Inputs X4 ... X7	
Bit	Contact
0	Pin4_X4
1	Reserved
2	Pin4_X5
3	Reserved
4	Pin4_X6
5	Reserved
6	Pin4_X7

Byte 1 Inputs X4 ... X7	
Bit	Contact
7	Reserved

9 Maintenance and cleaning

 WARNING**Material damage due to defective or damaged appliances.**

The function of the devices is not guaranteed.

- a) Replace defective or damaged devices.
-

Cleaning the appliance:

- Only use oil-free compressed air or ethanol
- Only use non-fibrous materials (e.g. leather cloth)
- Do not use contact spray

10 Annex**10.1 Accessories****10.1.1 Tools**

Designation	Art. no.
M8 installation wrench set SW 9	CAM8.WS9-11238649
M12 installation wrench set SW 13	CAM12-W13-11238690



III. 6: Assembly wrench



INFO
PRODUCTS AND ACCESSORIES

You will encounter a large product selection at: <https://www.baumer.com>

